

9500 RF DECK
 RF CONCEPTS LLC
 BOULDER, COLORADO 80503

6

5

4

3

2

1

REVISION HISTORY

REV	ECO NO.	DESCRIPTION	CHANGED BY & DATE	CHECKED BY & DATE	EFFECTIVITY DATE

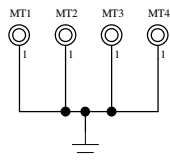
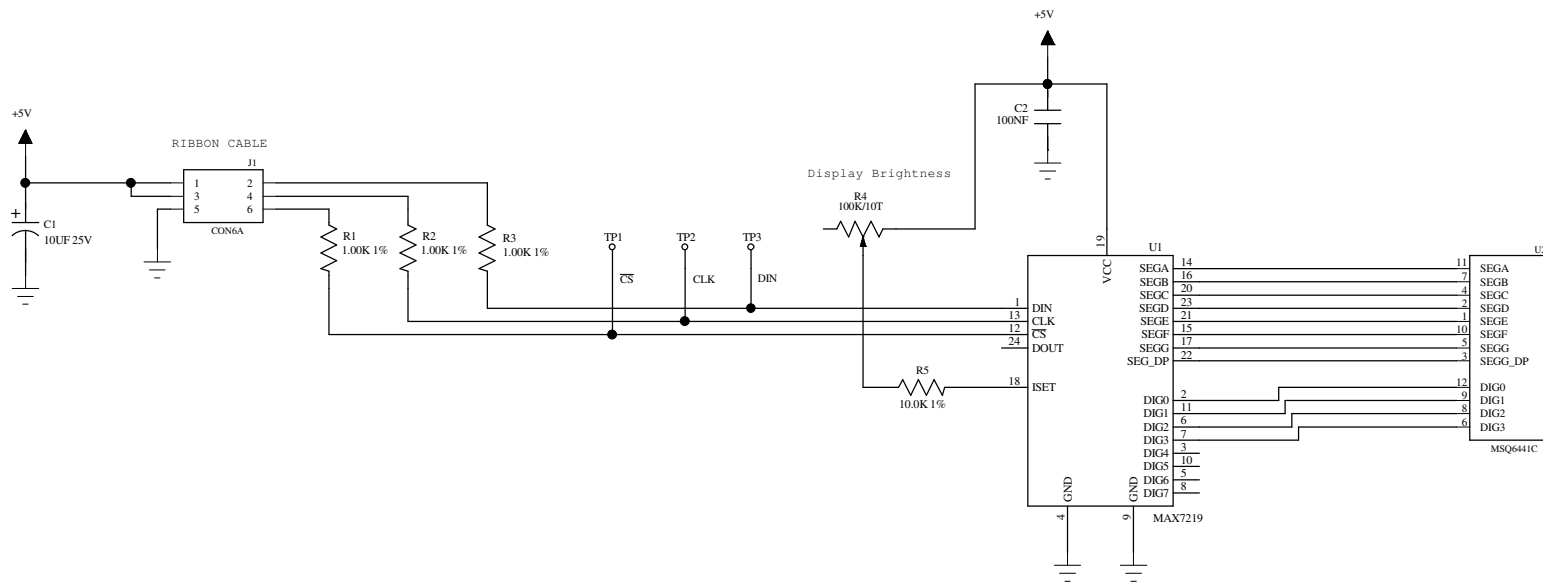

COMPONENT TYPE = ELECTRICAL
 CATEGORY = CUSTOM
 DESIGNATION = NONE

UNLESS OTHERWISE SPECIFIED
 DIMENSIONS ARE IN INCHES
 TOLERANCES ARE:
 XX +/- 0.01 ANGLE: 0.5
 XXX +/- 0.001

PROPRIETARY NOTICE:
 THIS DOCUMENT AND DATA DISCLOSED
 HEREIN AND HEREWITH IS NOT
 TO BE REPRODUCED, USED,
 OR DISCLOSED IN WHOLE OR
 ANY PART TO ANYONE WITHOUT
 THE PERMISSION OF ALPHA RADIO PRODUCTS LLC.

PROJECT NO. 9500
 ENGINEER: G. HARDMANN DATE: 08/16/05
 DRAWN BY: B. FOCKEN DRAFT DATE: 08/16/05

DRAWING FILE: BCX-X418_REV_1.SCH

PADS POWERLOGIC DRAWING

ALPHA RADIO PRODUCTS LLC
 6185 ARAPAHOE RD.
 BOULDER, COLORADO 80303
 PHONE: (303) 473-9232
 FAX: (303) 473-9660

TITLE: SCH, 9500, FRONT PANEL DIGITAL DISPLAY

SIZE B	DRAWING # BCX-X418	REV. 1
--------	--------------------	--------

SCALE SHEET 1 OF 1

D

C

B

A

6

5

4

3

2

1

REVISION HISTORY

REV	ECO NO.	DESCRIPTION	CHANGED BY & DATE	CHECKED BY & DATE	EFFECTIVITY DATE

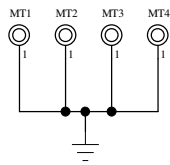
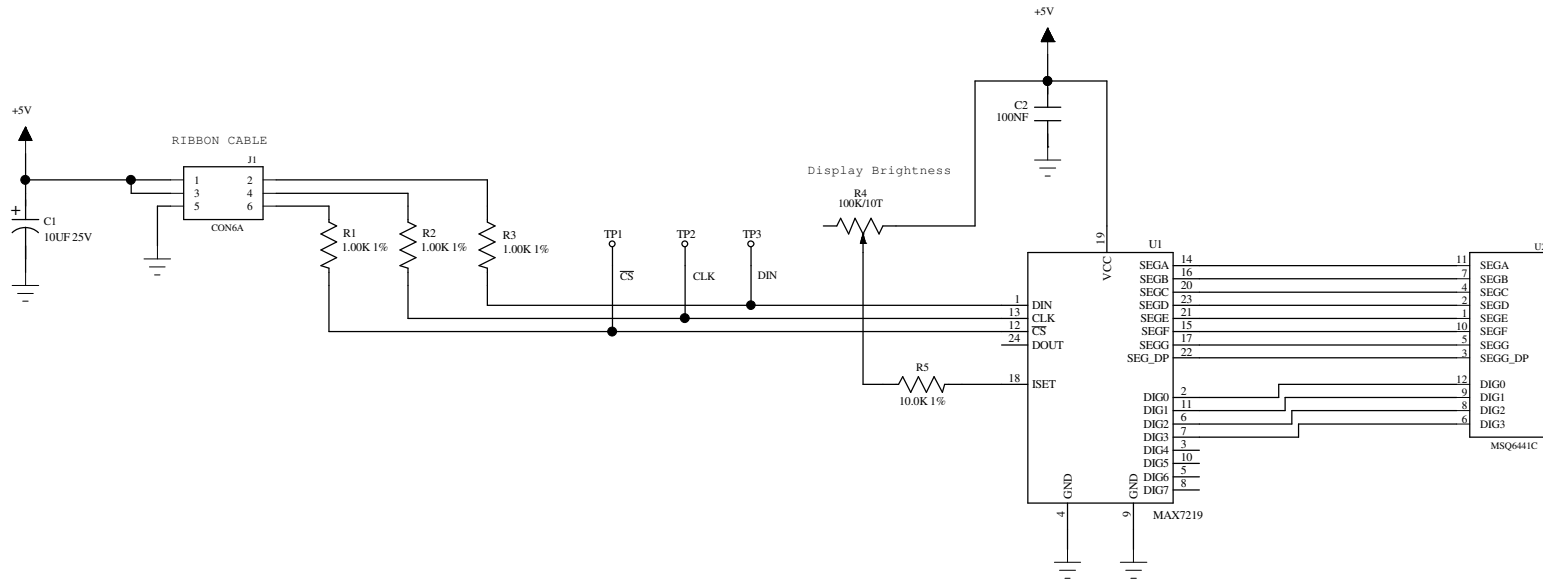

COMPONENT TYPE = ELECTRICAL
 CATEGORY = CUSTOM
 DESIGNATION = NONE

UNLESS OTHERWISE SPECIFIED
 DIMENSIONS ARE IN INCHES
 TOLERANCES ARE:
 XX +/- 0.01 ANGLE: 0.5
 XXX +/- 0.001

PROPRIETARY NOTICE:
 THIS DOCUMENT AND DATA DISCLOSED
 HEREIN AND HEREWITH IS NOT
 TO BE REPRODUCED, USED,
 OR DISCLOSED IN WHOLE OR
 ANY PART TO ANYONE WITHOUT
 THE PERMISSION OF ALPHA RADIO PRODUCTS LLC.

PROJECT NO. 9500
 ENGINEER: G. HARDMANN DATE: 08/16/05
 DRAWN BY: B. FOCKEN DRAFT DATE: 08/16/05

DRAWING FILE: BCX-X418_REV_1.SCH

PADS POWERLOGIC DRAWING

ALPHA RADIO PRODUCTS LLC
 6185 ARAPAHOE RD.
 BOULDER, COLORADO 80303
 PHONE: (303) 473-9232
 FAX: (303) 473-9660

TITLE: SCH, 9500, FRONT PANEL DIGITAL DISPLAY

SIZE B DRAWING # BCX-X418 REV. 1

SCALE SHEET 1 OF 1

6

5

4

3

2

1

D

D

C

C

B

B

A

A

REVISION HISTORY

REV	ECO NO.	DESCRIPTION	CHANGED BY & DATE	CHECKED BY & DATE	EFFECTIVITY DATE
1		DEVELOPMENT	BWF 09/01/05	GEH 09/01/05	09/01/05
2		INITIAL RELEASE	BWF 07/15/06	GEH 07/15/06	07/15/06
3		ADD POWER SUPPLY	BWF 07/28/06	GEH 07/28/06	07/28/06
3.1		CHANGES TO VALUES AND POLARITY	BWF 10/17/06	GEH 10/17/06	10/17/06

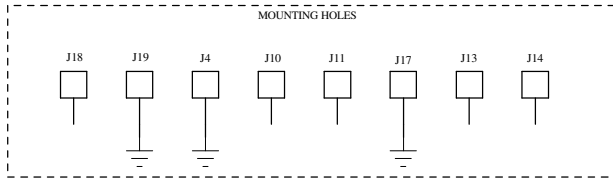
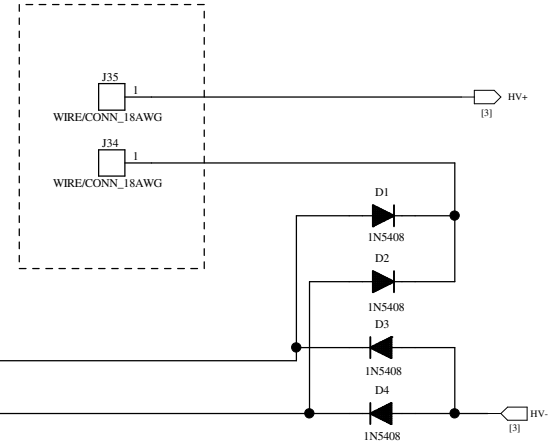
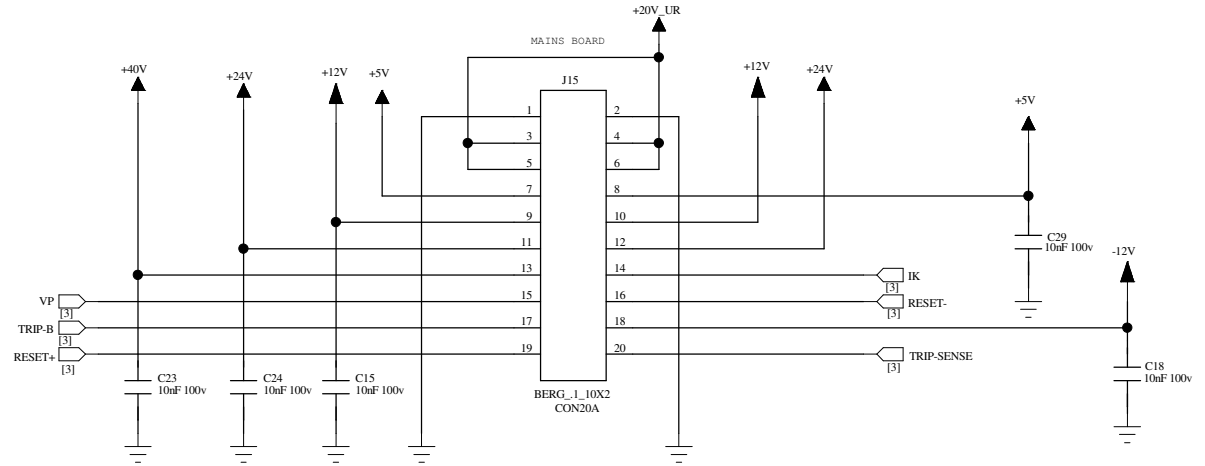
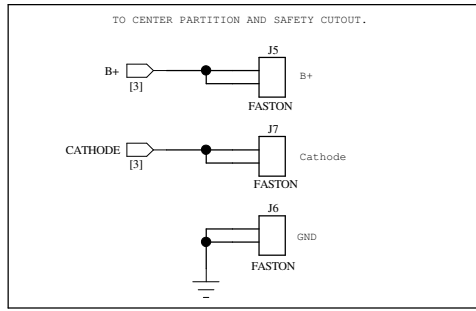
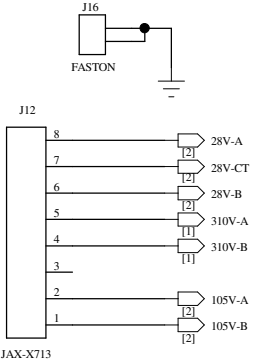

COMPONENT TYPE = ELECTRICAL
 CATEGORY = CUSTOM
 DESIGNATION = NONE

UNLESS OTHERWISE SPECIFIED
 DIMENSIONS ARE IN INCHES
 TOLERANCES ARE:
 XX ±0.01 ANGLE: 0.5
 XXX ±0.001

PROPRIETARY NOTICE:
 THIS DOCUMENT AND DATA DISCLOSED
 HEREIN AND HEREWITH IS NOT
 TO BE REPRODUCED, USED,
 OR DISCLOSED IN WHOLE OR
 ANY PART TO ANYONE WITHOUT
 THE PERMISSION OF ALPHA RADIO PRODUCTS LLC.

PROJECT NO. 9500
 ENGINEER: G. HARDMANN DATE: 10/17/06
 DRAWN BY: B. FOCKEN DRAFT DATE: 10/17/06

DRAWING FILE: BCX-X419_REV_A.SCH

PADS POWERLOGIC DRAWING

ALPHA RADIO PRODUCTS LLC
 6185 ARAPAHOE RD. BOULDER, COLORADO 80303
 PHONE: (303) 473-9232 FAX: (303) 473-9660

TITLE: SCH, 9500, HIGH VOLTAGE POWER SUPPLY

SIZE B DRAWING # BCX-X419 REV. A

SCALE SHEET 1 OF 3

6

5

4

3

2

1

D

D

C

C

B

B

A

A

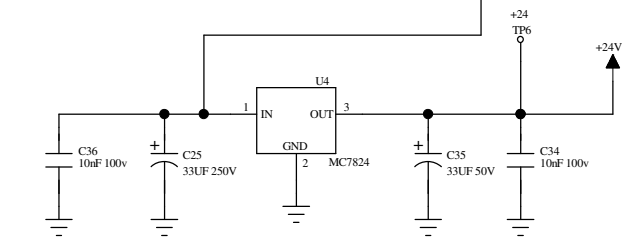
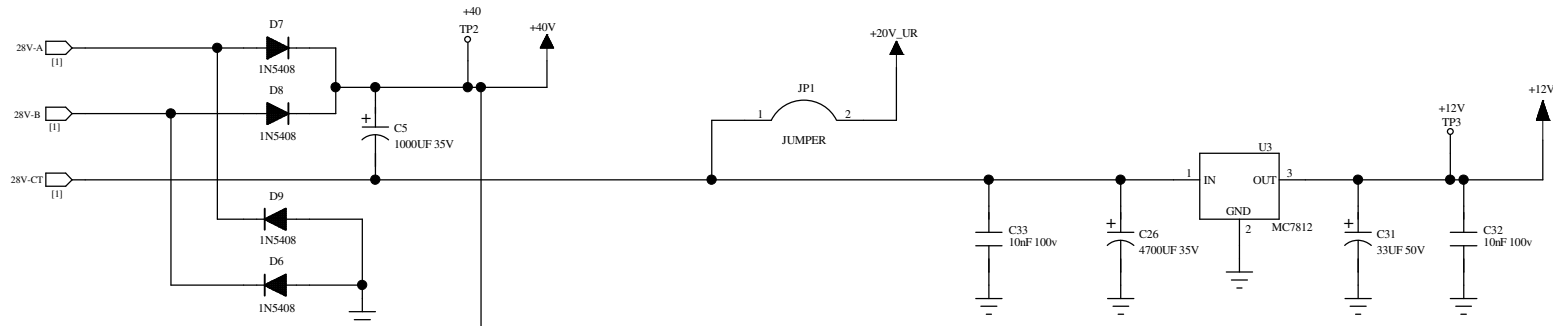
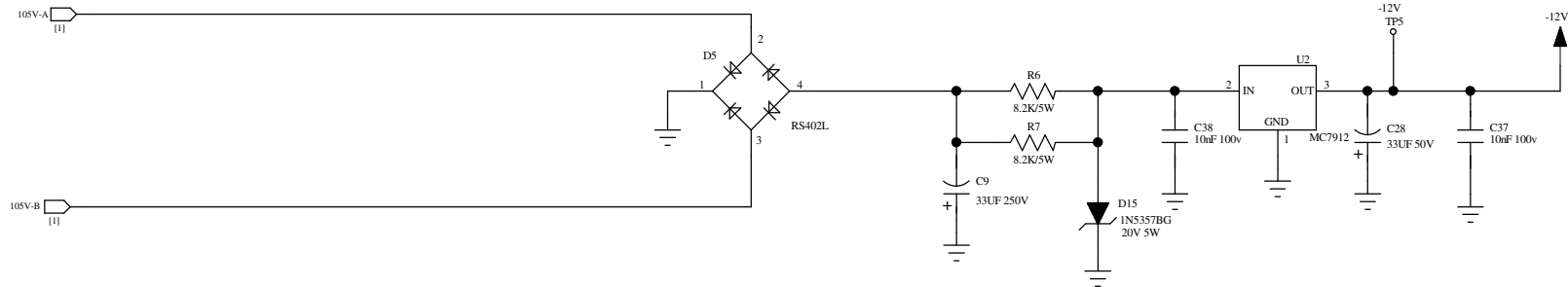

COMPONENT TYPE = ELECTRICAL
 CATEGORY = CUSTOM
 DESIGNATION = NONE

UNLESS OTHERWISE SPECIFIED
 DIMENSIONS ARE IN INCHES
 TOLERANCES ARE:
 XXX +/- 0.01 ANGLE: 0.5
 XXXX +/- 0.001

PROPRIETARY NOTICE:
 THIS DOCUMENT AND DATA DISCLOSED
 HEREIN AND HEREWITH IS NOT
 TO BE REPRODUCED, USED,
 OR DISCLOSED IN WHOLE OR
 ANY PART TO ANYONE WITHOUT
 THE PERMISSION OF ALPHA RADIO PRODUCTS LLC.

PROJECT NO. 9500
 ENGINEER: G. HARDMANN DATE: 10/17/06
 DRAWN BY: B. FOCKEN DRAFT DATE: 10/17/06

DRAWING FILE:
 BCX-X418_REV_A.SCH

PADS POWERLOGIC DRAWING

ALPHA RADIO PRODUCTS LLC
 6185 ARAPAHOE RD.
 BOULDER, COLORADO 80303
 PHONE: (303) 473-9232
 FAX: (303) 473-9660

TITLE:
 SCH, 9500, HIGH VOLTAGE POWER SUPPLY

SIZE B DRAWING # BCX-X419 REV. A

SCALE SHEET 2 OF 3

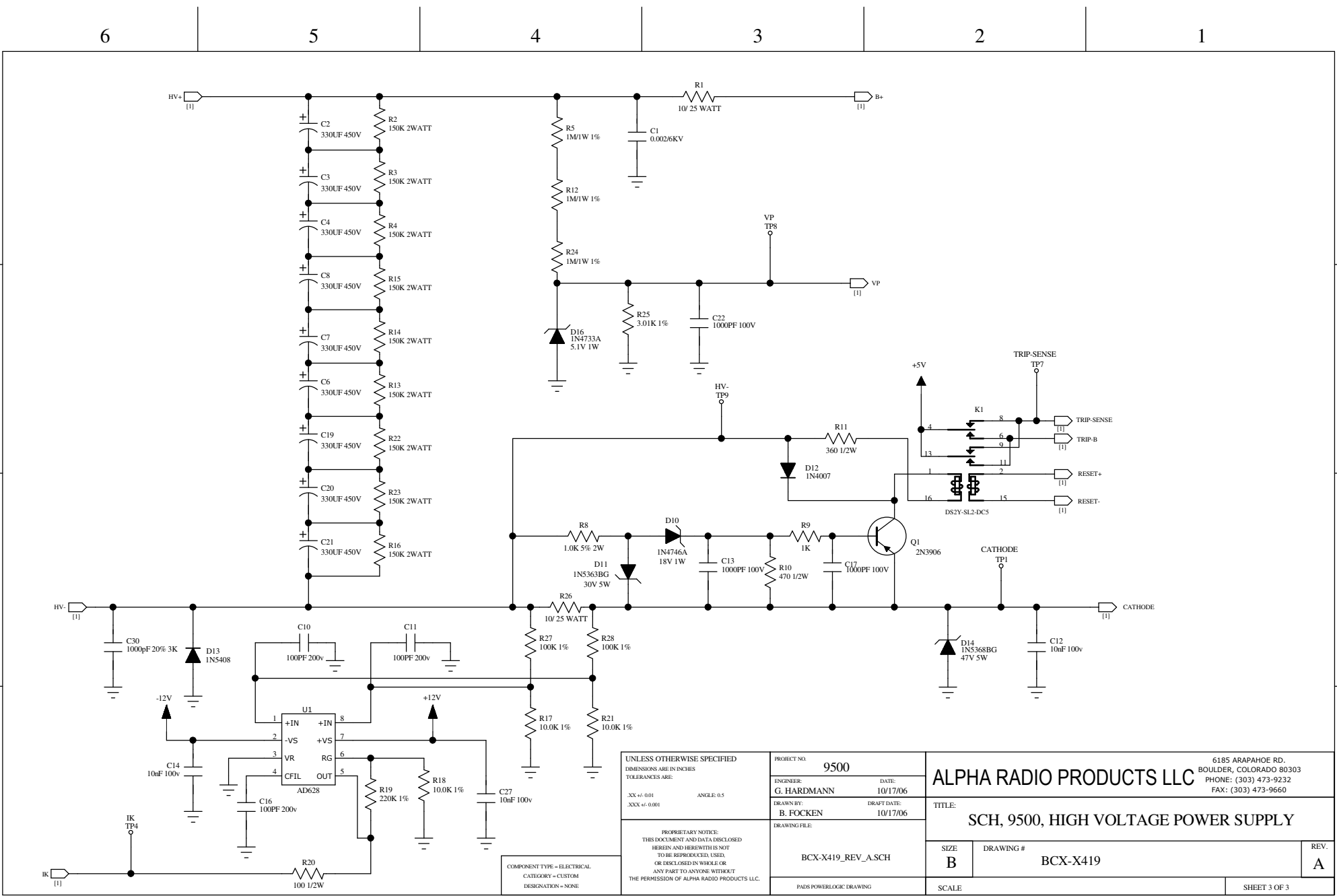

UNLESS OTHERWISE SPECIFIED
 DIMENSIONS ARE IN INCHES
 TOLERANCES ARE:
 XX +/- 0.01 ANGLE: 0.5
 XXX +/- 0.001

PROPRIETARY NOTICE:
 THIS DOCUMENT AND DATA DISCLOSED
 HEREIN AND HEREWITH IS NOT
 TO BE REPRODUCED, USED,
 OR DISCLOSED IN WHOLE OR
 ANY PART TO ANYONE WITHOUT
 THE PERMISSION OF ALPHA RADIO PRODUCTS LLC.

PROJECT NO. **9500**
 ENGINEER: **G. HARDMANN** DATE: **10/17/06**
 DRAWN BY: **B. FOCKEN** DRAFT DATE: **10/17/06**

DRAWING FILE:
BCX-X419_REV_A.SCH

PADS POWERLOGIC DRAWING

ALPHA RADIO PRODUCTS LLC 6185 ARAPAHOE RD.
 BOULDER, COLORADO 80303
 PHONE: (303) 473-9232
 FAX: (303) 473-9660

TITLE:
SCH, 9500, HIGH VOLTAGE POWER SUPPLY

SIZE B	DRAWING # BCX-X419	REV. A
------------------	------------------------------	------------------

SCALE SHEET 3 OF 3

COMPONENT TYPE = ELECTRICAL
 CATEGORY = CUSTOM
 DESIGNATION = NONE

6

5

4

3

2

1

D

C

B

A

D

C

B

A

REVISION HISTORY					
REV	ECO NO.	DESCRIPTION	CHANGED BY & DATE	CHECKED BY & DATE	EFFECTIVITY DATE
1		INITIAL RELEASE	BWF 09/07/05	BWF 09/07/05	09/07/05
2		CHANGE TO PROCESSOR PIN OUT	BWF 12/21/05	BWF 12/21/05	12/21/05
2.1		CHANGED RELAYS	BWF 12/29/05	GEH 12/29/05	12/29/05
2.2/3		CHANGE PARTS	BWF 04/11/06	GEH 04/11/06	04/11/06
4		CHANGE AC SENSE CIRCUIT	BWF 07/24/06	GEH 07/24/06	07/24/06
5		ADD POWER SUPPLY	BWF 07/31/06	GEH 07/31/06	07/31/06
A		RELEASE TO MFG	BWF 11/13/07	GEH 11/13/07	11/13/07

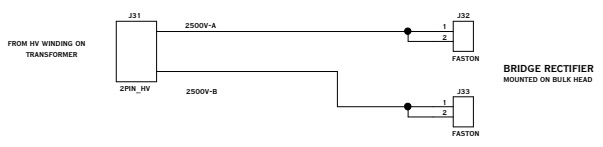
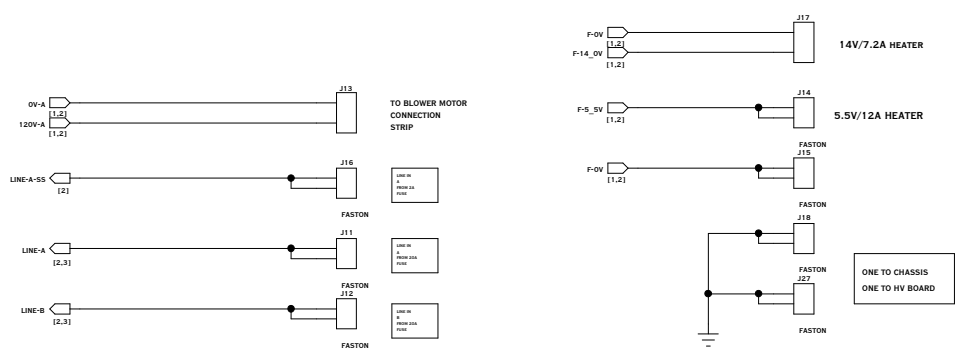
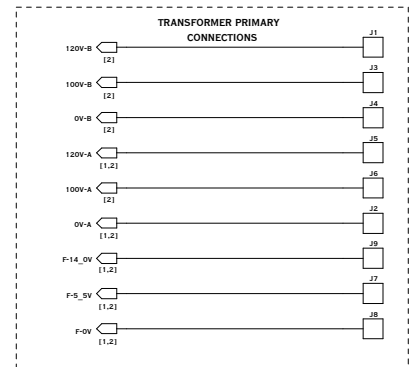
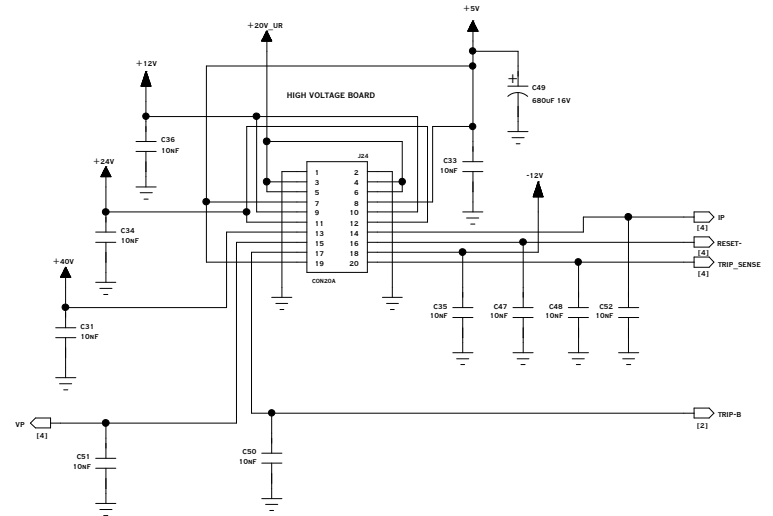
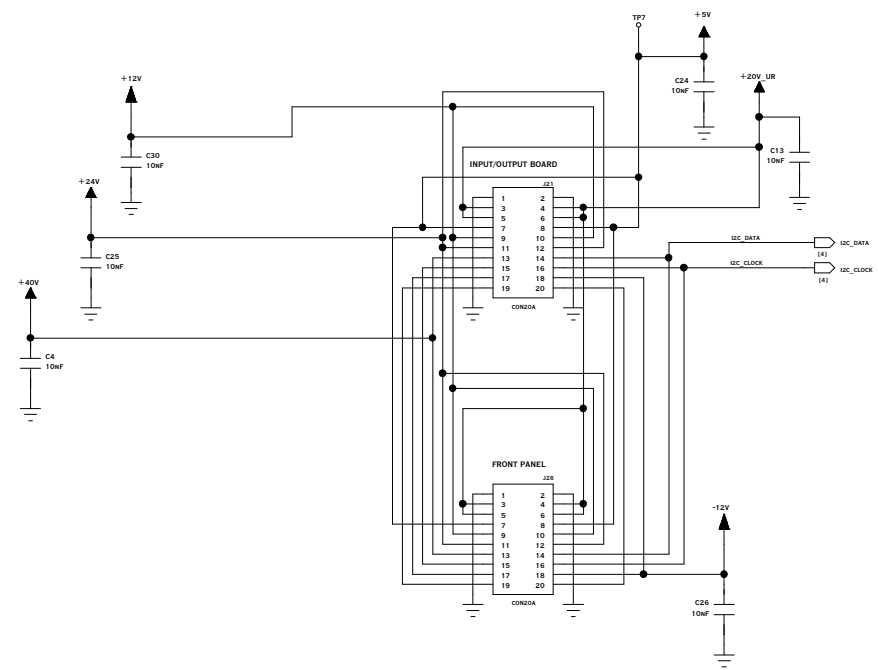

UNLESS OTHERWISE SPECIFIED DIMENSIONS ARE IN INCHES TOLERANCES ARE: XX .XX ± 0.01 ANGLE 0.5 SEE FIG. 0001	PROJECT NO. 9500	ALPHA RADIO PRODUCTS LLC 6185 ARAPAHOE RD. BOULDER, COLORADO 80303 PHONE: (303) 473-9232 FAX: (303) 473-9560
	ENGINEER: G. HARDMAN DATE: 11/13/07	
DESIGNED BY: B. FOCKEN DATE: 11/13/07	TITLE: SCH, 9500, AC MAINS/LVPS	SIZE C
PROPRIETARY NOTICE: THIS DOCUMENT AND DATA DISCLOSED HEREIN AND HEREIN IS NOT TO BE REPRODUCED, COPIED, OR DISCLOSED IN WHOLE OR ANY PART TO ANYONE WITHOUT THE PERMISSION OF ALPHA RADIO PRODUCTS LLC.	DRAWING FILE: BCX-X420_REV_A.SCH	DRAWING # BCX-X420
COMPONENT TYPE - ELECTRICAL CATEGORY - CUSTOM DESIGNATION - NONE	PAGE NUMBER/DRAWING	SCALE
		REV. A

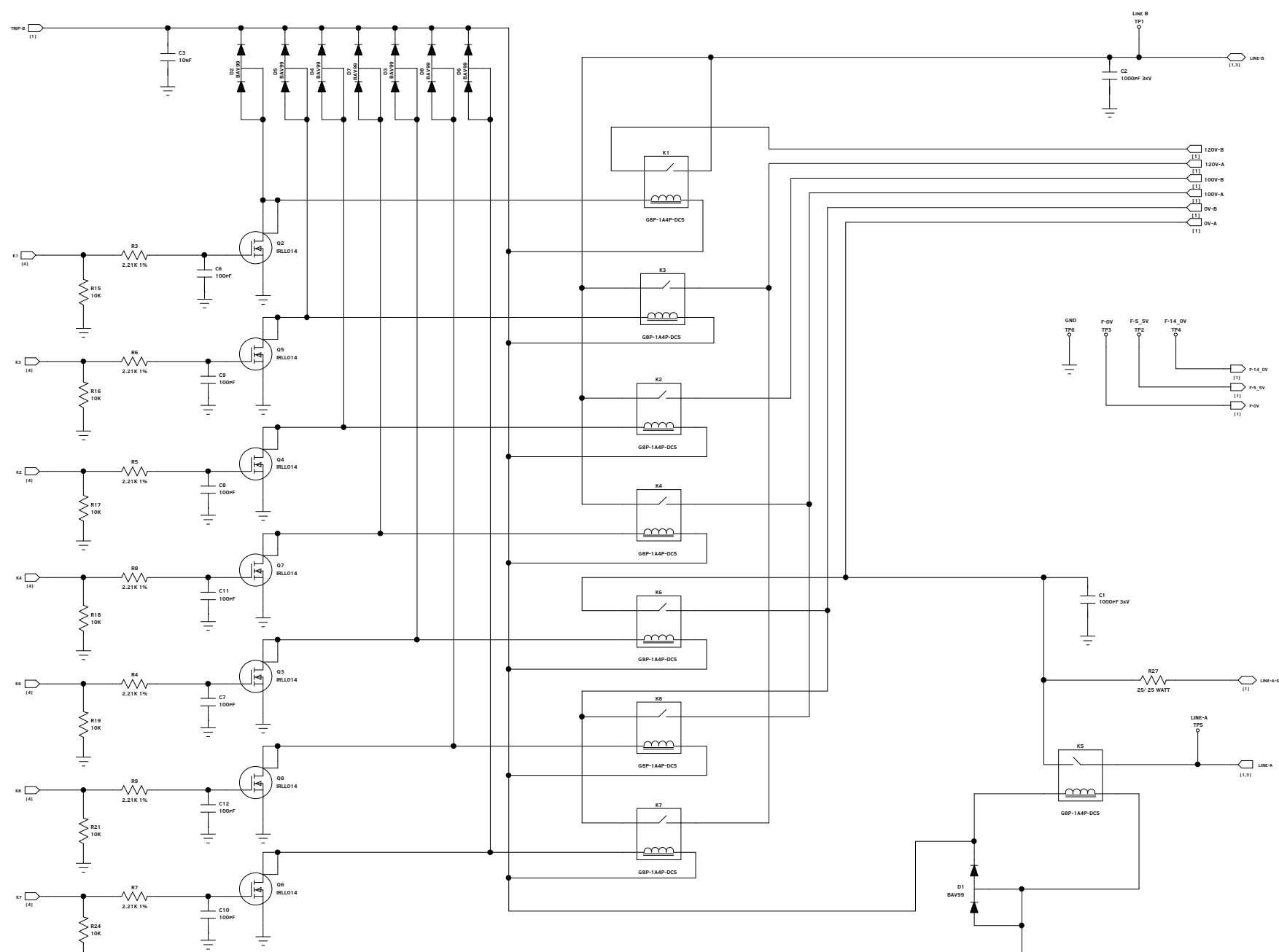

UNLESS OTHERWISE SPECIFIED DIMENSIONS ARE IN INCHES TOLERANCES ARE: XX .XX ± 0.01 ANGLE: 0.5 SEE FIG. 0-0001	PROJECT NO. 9500 ENGINEER: G. HARDMAN DRAWN BY: B. FOCKEN	DATE: 11/13/07 DRAW DATE: 11/13/07	ALPHA RADIO PRODUCTS LLC 6185 ASAPAHOE RD. BOULDER, COLORADO 80303 PHONE: (303) 473-9532 FAX: (303) 473-9560	
	PROPRIETARY NOTICE: THIS DOCUMENT AND DATA DISCLOSED HEREIN AND HEREWITH IS NOT TO BE REPRODUCED, COPIED, OR DISCLOSED IN WHOLE OR ANY PART TO ANYONE WITHOUT THE PERMISSION OF ALPHA RADIO PRODUCTS LLC.	DRAWING FILE: BCX-X420_REV_A.SCH	TITLE: SCH, 9500, AC MAINS/LVPS	SIZE C DRAWING # BCX-X420
COMPONENT TYPE - ELECTRICAL CATEGORY - CUSTOMER DESIGNATION - NONE	PADS POWERLOGIC DRAWING	SCALE	SHEET 2 OF 4	

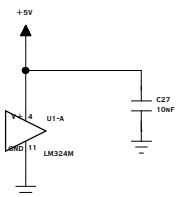
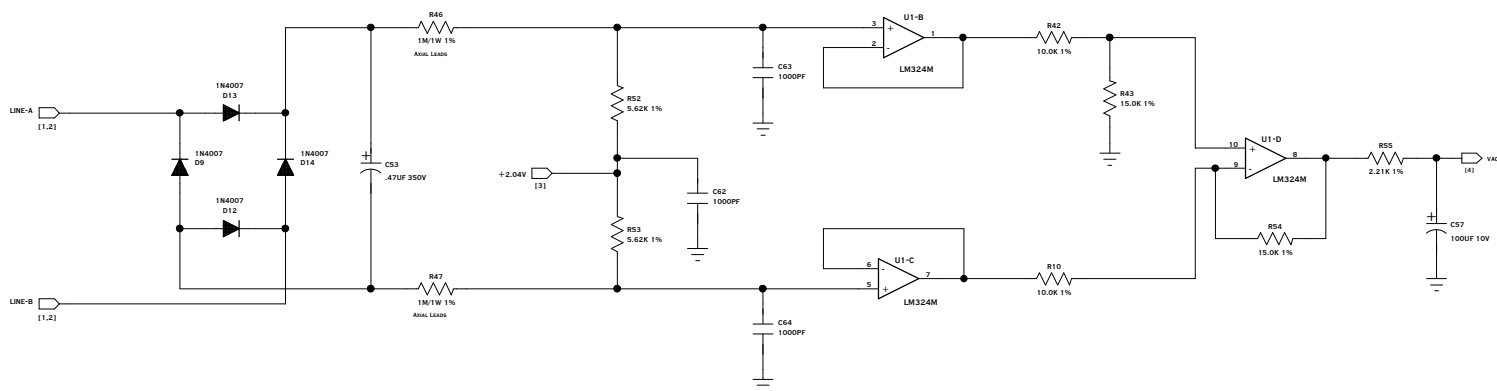
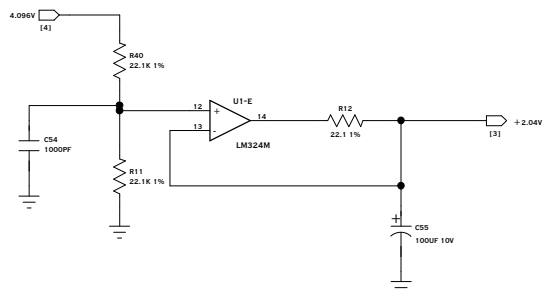

COMPONENT TYPE - ELECTRICAL
 CATEGORY - CUSTOM
 DESIGNATION - NONE

<small>UNLESS OTHERWISE SPECIFIED</small> <small>DIMENSIONS ARE IN INCHES</small> <small>TOLERANCES ARE:</small> <small>XX +/- 0.01</small> <small>ANGLE: 0.5</small> <small>XXX +/- 0.001</small>	<small>PROJECT NO.</small> 9500	ALPHA RADIO PRODUCTS LLC <small>6185 ARAPAHOE RD.</small> <small>BOULDER, COLORADO 80303</small> <small>PHONE: (303) 473-9232</small> <small>FAX: (303) 473-9660</small>
	<small>ENGINEER:</small> G. HARDMAN <small>DATE:</small> 11/13/07	
<small>PROPRIETARY NOTICE:</small> <small>THIS DOCUMENT AND DATA DISCLOSED</small> <small>HEREIN AND HEREIN IS NOT</small> <small>TO BE REPRODUCED, COPIED,</small> <small>OR DISCLOSED IN WHOLE OR</small> <small>ANY PART TO ANYONE WITHOUT</small> <small>THE PERMISSION OF ALPHA RADIO PRODUCTS LLC.</small>	<small>DRAWN BY:</small> B. FOCKEN <small>DATE:</small> 11/13/07	<small>TITLE:</small> SCH, 9500, AC MAINS/LVPS
<small>PAGE NUMBER/SCHEMATIC</small> BCX-X420_REV_A.SCH	<small>SCALE</small> 	<small>SIZE</small> C
<small>REV.</small> A	<small>DRAWING #</small> BCX-X420	<small>REV.</small> A
<small>SHEET 3 OF 4</small>		

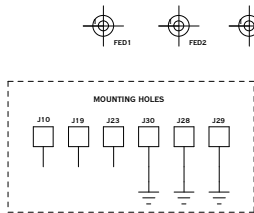
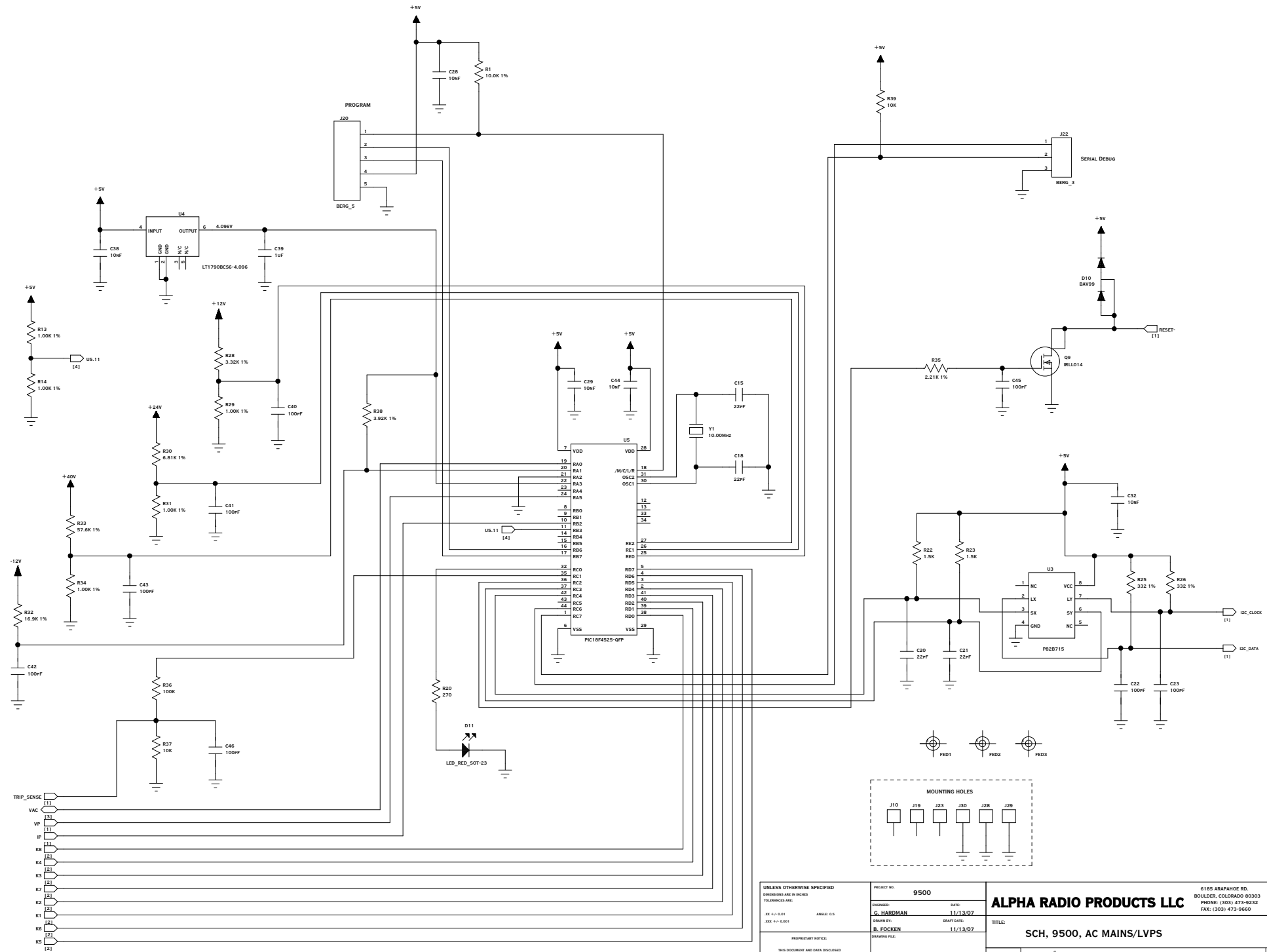

<small>UNLESS OTHERWISE SPECIFIED DIMENSIONS ARE IN INCHES TOLERANCES ARE:</small> <small>XX +/- 0.01 ANGLE: 0.5 DEC +/- 0.0051</small>	<small>PROJECT NO.</small> 9500	ALPHA RADIO PRODUCTS LLC <small>6185 ARAPAHOE RD. BOULDER, COLORADO 80303 PHONE: (303) 473-9532 FAX: (303) 473-9660</small>
	<small>ENGINEER:</small> G. HARDMAN <small>DATE:</small> 11/13/07	
	<small>DRAWN BY:</small> B. FOCKEN <small>DATE:</small> 11/13/07	
<small>PROPERTY NOTICE:</small> <small>THIS DOCUMENT AND DATA DISCLOSED HEREIN AND HEREWITH IS NOT TO BE REPRODUCED, COPIED, OR DISCLOSED IN WHOLE OR ANY PART TO ANYONE WITHOUT THE PERMISSION OF ALPHA RADIO PRODUCTS LLC.</small>	<small>TITLE:</small> SCH, 9500, AC MAINS/LVPS	<small>SIZE:</small> C <small>DRAWING #:</small> BCX-X420 <small>REV.:</small> A
<small>COMPONENT TYPE - ELECTRICAL CATEGORY - CUSTOMER DESIGNATION - NONE</small>	<small>PAGE POWERBLOCK DRAWING</small>	<small>SCALE</small>
<small>SHEET 4 OF 4</small>		

REVISION HISTORY					
REV	ECO NO.	DESCRIPTION	CHANGED BY & DATE	CHECKED BY & DATE	EFFECTIVITY DATE
1		INITIAL RELEASE	BWF 11/09/06	GEH 11/09/06	11/09/06
2		CHANGES TO WATT METERS	BWF 12/08/06	GEH 12/08/06	12/08/06
3		CHANGES TO WATT METERS AND PROCESSOR	BWF 01/03/07	GEH 01/03/07	01/03/07

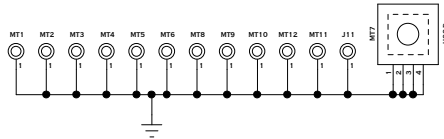
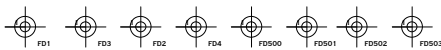
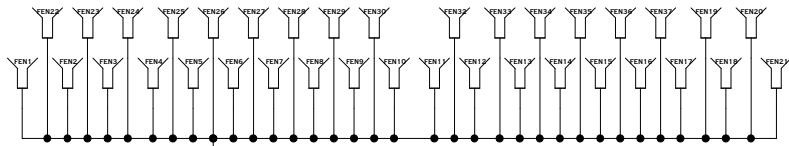
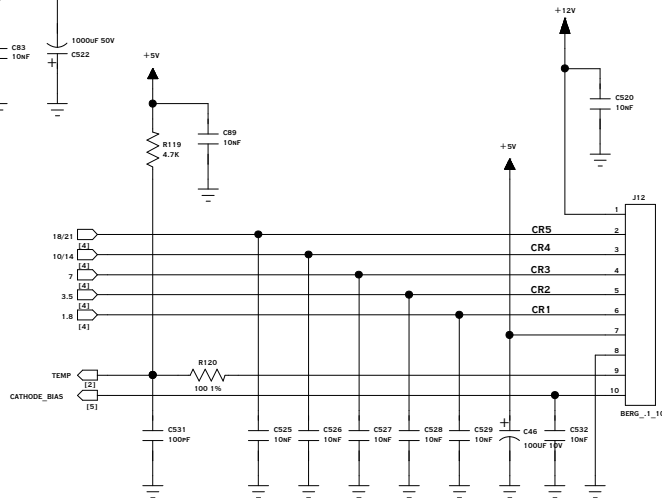
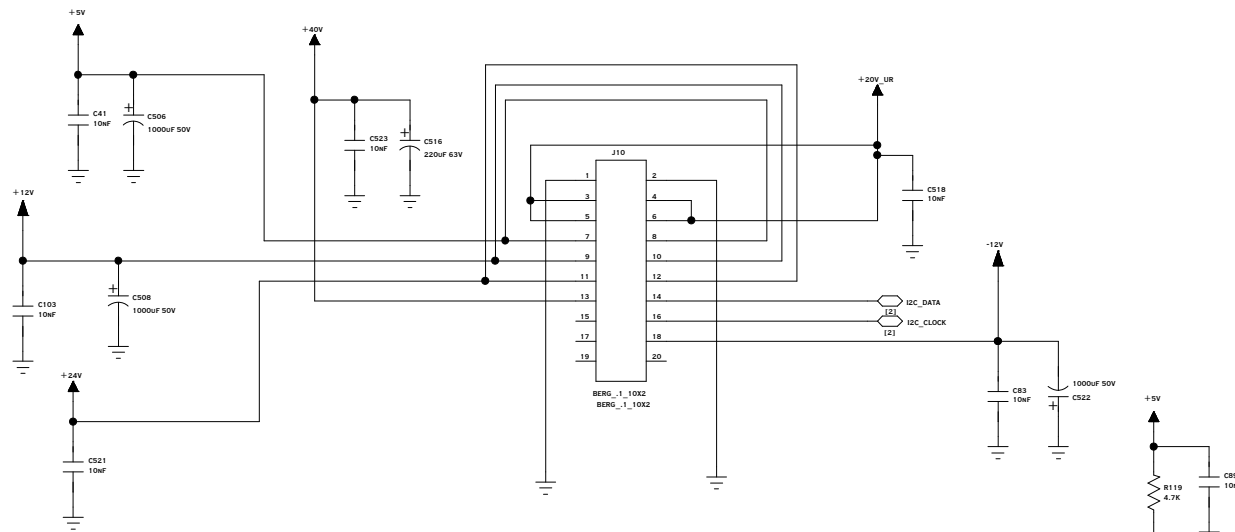
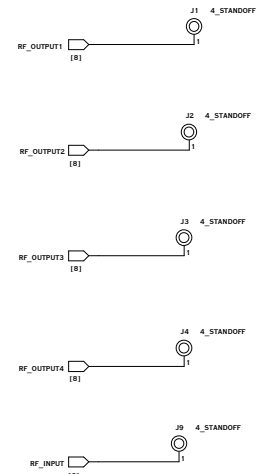
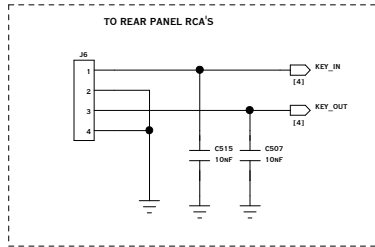

UNLESS OTHERWISE SPECIFIED DIMENSIONS ARE IN INCHES TOLERANCES ARE: .XX +/- 0.01 ANGLE: 0.5 .XX +/- 0.001 PROPRIETARY NOTICE: THIS DOCUMENT AND DATA DISCLOSED HEREIN AND HEREWITH IS NOT TO BE REPRODUCED, COPIED, OR DISCLOSED IN WHOLE OR ANY PART TO ANYONE WITHOUT THE PERMISSION OF ALPHA RADIO PRODUCTS LLC.	PROJECT NO. 9500 ENGINEER: S. HARMAN DRAWN BY: B. FOCKEN DATE: 07/25/08 DRAW DATE: 07/25/08	6185 ARAPAHOE RD. BOULDER, COLORADO 80303 PHONE: (303) 473-9232 FAX: (303) 473-9660
	TITLE: SCH, 9500, MAIN CONTROLLER PCB SIZE: C DRAWING #: BCX-X421 CONNECTORS SCALE:	REV: A SHEET 1 OF 8

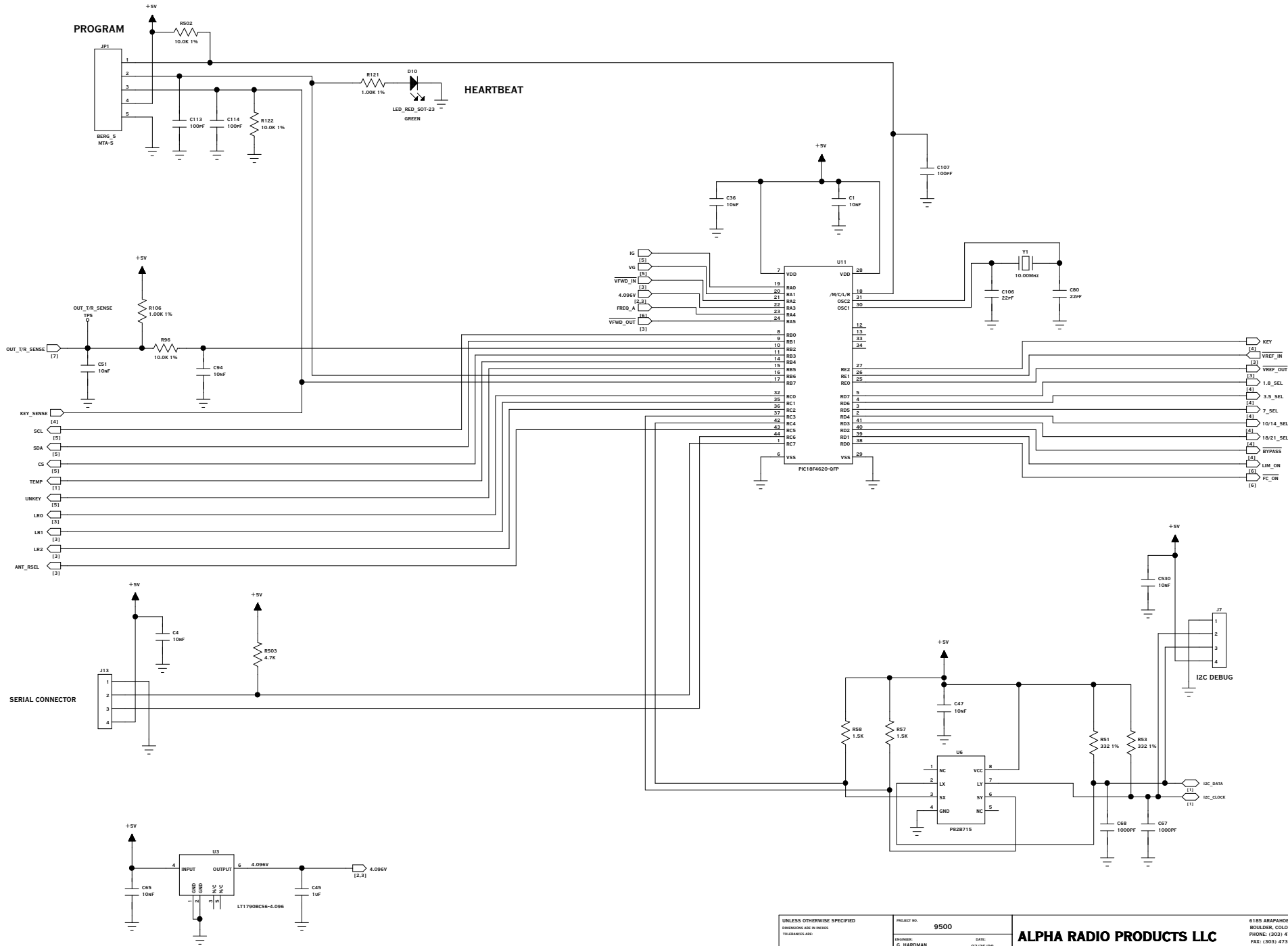

UNLESS OTHERWISE SPECIFIED DIMENSIONS ARE IN INCHES TOLERANCES ARE: .XX - 0.01 ANGLE: 0.5 .XX - 0.001	PROJECT NO. 9500	ALPHA RADIO PRODUCTS LLC 6185 ARAPAHOE RD. BOULDER, COLORADO 80303 PHONE: (303) 473-9232 FAX: (303) 473-9660
	ENGINEER: G. HARDMAN DATE: 07/25/08 DRAWN BY: B. FOCKEN DATE: 07/25/08	
PROPRIETARY NOTICE: THIS DOCUMENT AND DATA DISCLOSED HEREIN AND HEREIN IS NOT TO BE REPRODUCED, COPIED, OR DISCLOSED IN WHOLE OR ANY PART TO ANYONE WITHOUT THE PERMISSION OF ALPHA RADIO PRODUCTS LLC.	DRAWING FILE: BCX-X421_REV_A_SCH	TITLE: SCH, 9500, MAIN CONTROLLER PCB
COMPONENT TYPE - ELECTRICAL CATEGORY - CUSTOM DESIGNATION - NONE	PAGE NUMBER/DRAWING 1	SIZE C DRAWING # BCX-X421 CONTROLLER 1 REV. A
SCALE		SHEET 2 OF 8

6

5

4

3

2

1

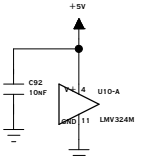
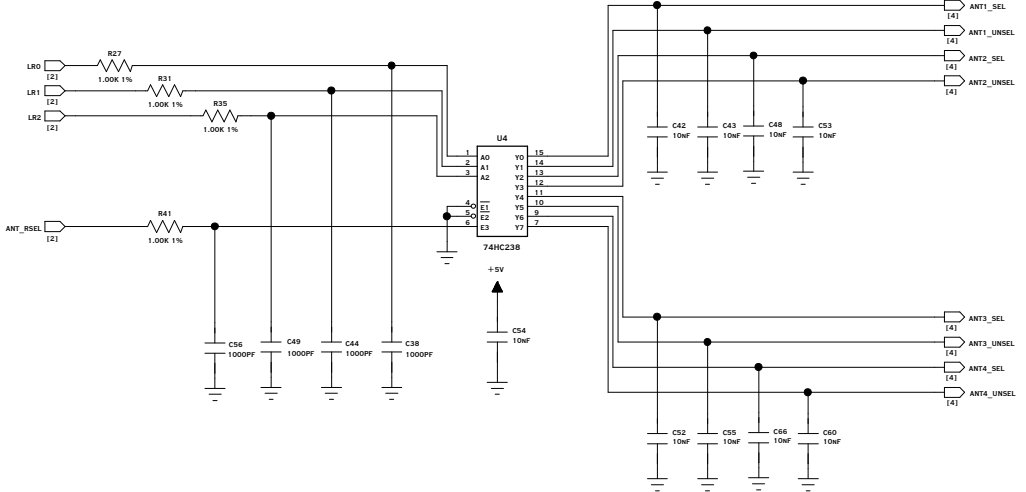
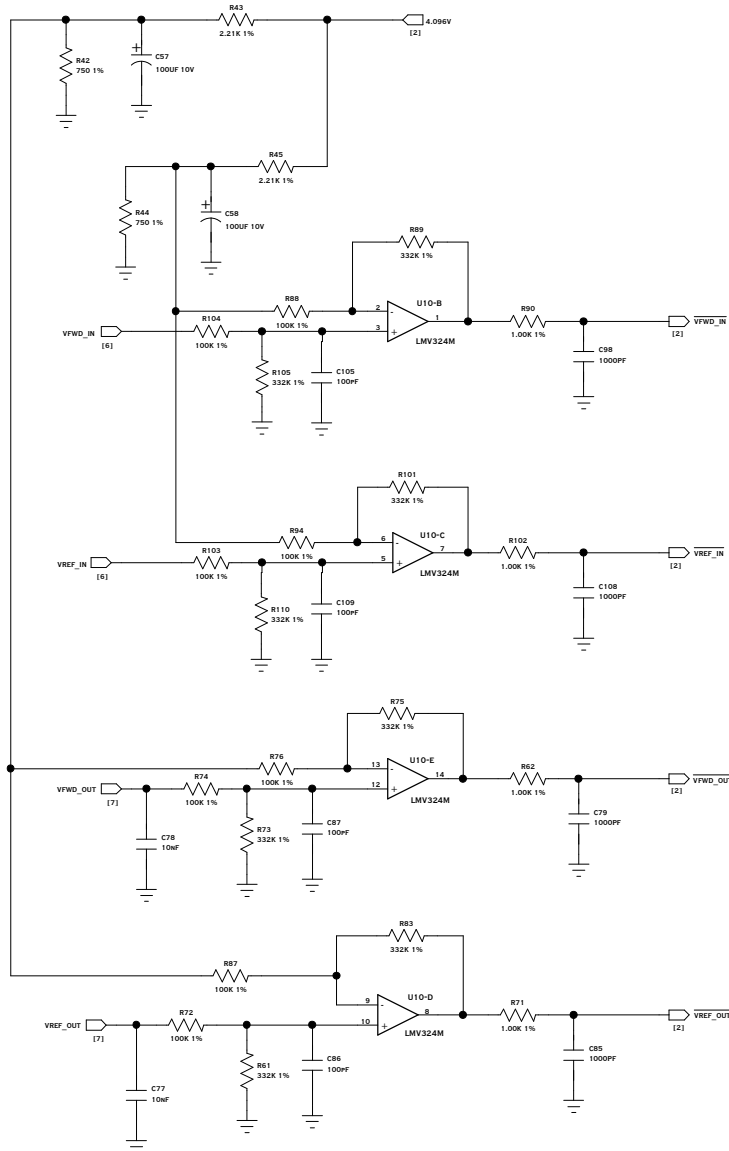

UNLESS OTHERWISE SPECIFIED DIMENSIONS ARE IN INCHES TOLERANCES ARE: X1: ±0.001 ANGLE: 0.5 X2: ±0.001	PROJECT NO. 9500	6185 ARAPAHOE RD. BOULDER, COLORADO 80303 PHONE: (303) 473-9232 FAX: (303) 473-9660	
	ENGINEER: G. HARDMAN	DATE: 07/25/08	TITLE: SCH. 9500, MAIN CONTROLLER PCB
	DRAWN BY: B. FOCKEN	DRAW DATE: 07/25/08	
PROPERTY NOTICE: THIS DOCUMENT AND DATA DISCLOSED HEREIN AND HEREWITH IS NOT TO BE REPRODUCED, COPIED, OR DISCLOSED IN WHOLE OR ANY PART TO ANYONE WITHOUT THE PERMISSION OF ALPHA RADIO PRODUCTS LLC.	DRAWING FILE: BCX-X421_REV_A_SCH	SIZE C	DRAWING # BCX-X421 CONTROLLER 2
COMPONENT TYPE - ELECTRICAL CATEGORY - CUSTOM DESIGNATION - NONE	PAGE POWERLOGIC DRAWING	SCALE	REV. A

SHEET 3 OF 8

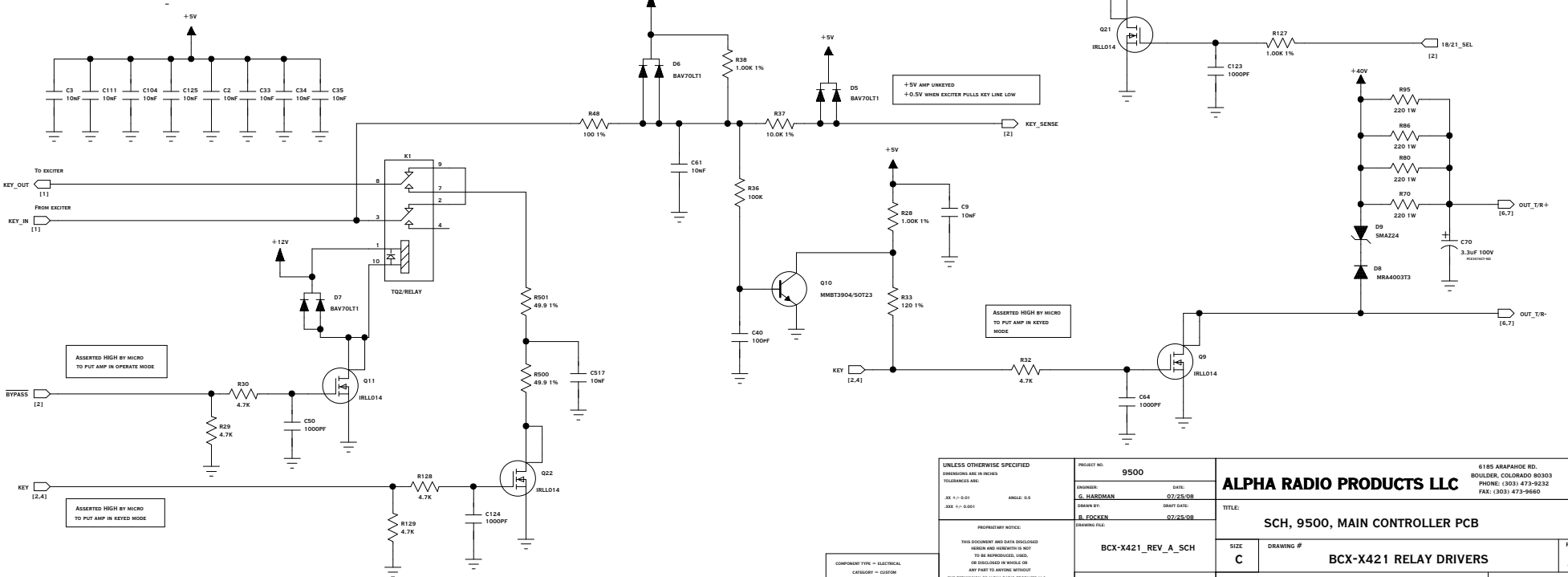
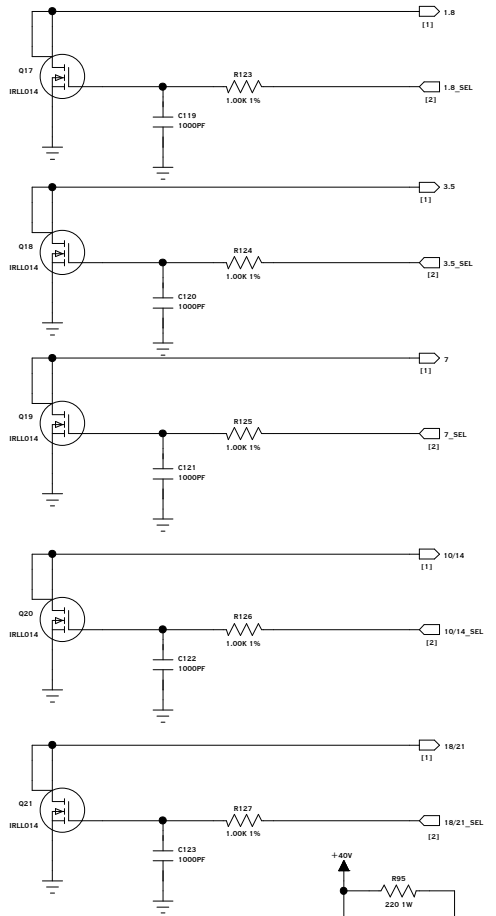
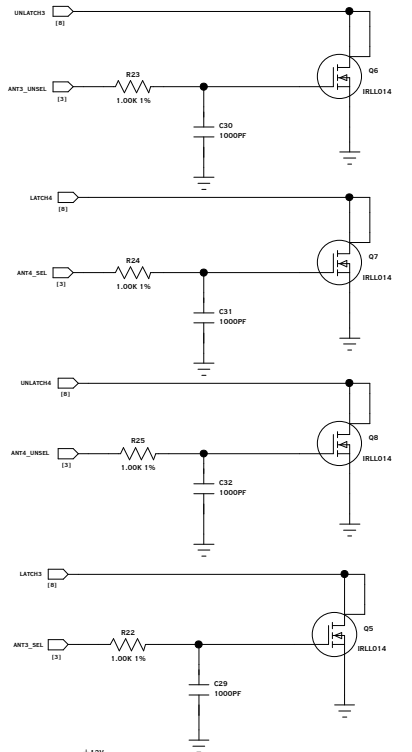
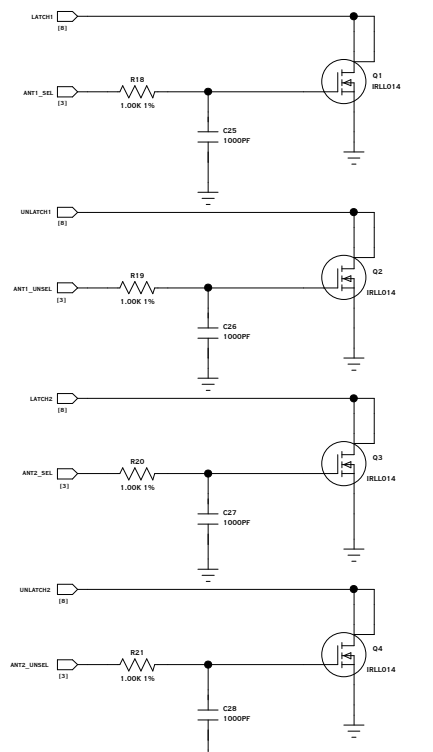

UNLESS OTHERWISE SPECIFIED DIMENSIONS ARE IN INCHES TOLERANCES ARE: XX +/- 0.01 XXX +/- 0.001	PROJECT NO. 9500	DATE: 07/25/09	ALPHA RADIO PRODUCTS LLC 6185 ARAPAHOE RD. BOULDER, COLORADO 80303 PHONE: (303) 473-9532 FAX: (303) 473-9660
	ENGINEER: G. HARMAN	DESIGNER: B. FOCKEN	
PROPRIETARY NOTICE: THIS DOCUMENT AND DATA DISCLOSED HEREIN AND HEREWITH IS NOT TO BE REPRODUCED, COPIED, OR DISCLOSED IN WHOLE OR ANY PART TO ANYONE WITHOUT THE PERMISSION OF ALPHA RADIO PRODUCTS LLC.	DRAWING FILE: BCX-X421_REV_A_SCH	DATE: 07/25/09	SCALE: SCALE
COMPONENT TYPE - ELECTRICAL CATEGORY - CUSTOM DESIGNATION - NONE	PAGE NUMBER/DRAWING BCX-X421_RELAY_DRIVERS	SIZE C	DRAWING # BCX-X421_RELAY_DRIVERS
		REV. A	SHEET 4 OF 8

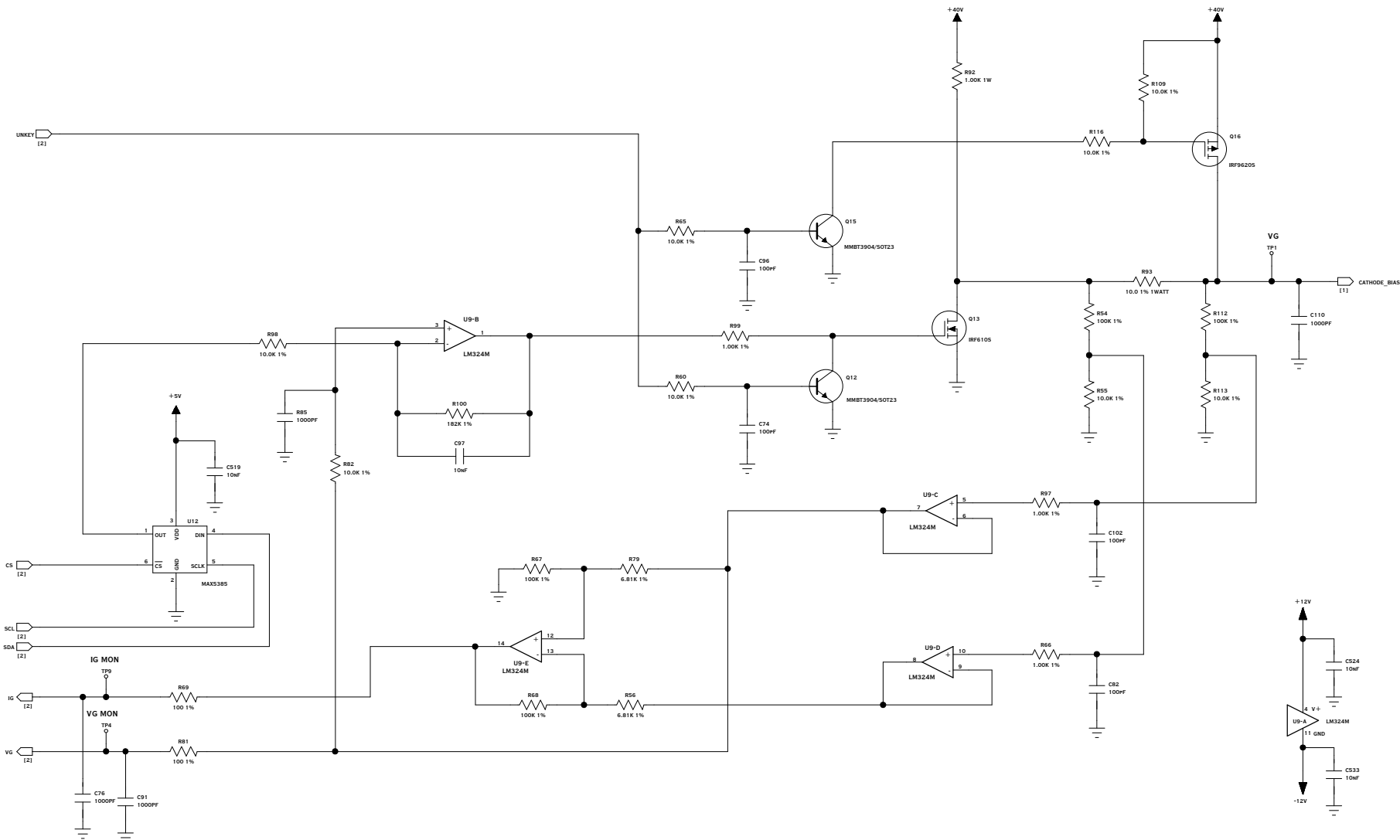

UNLESS OTHERWISE SPECIFIED DIMENSIONS ARE IN INCHES TOLERANCES ARE: .XX +/- 0.01 ANGLE: 0.5 .XX +/- 0.001 THIS DOCUMENT AND DATA DISCLOSED HEREIN AND HEREWITH IS NOT TO BE REPRODUCED, COPIED, OR DISCLOSED IN WHOLE OR ANY PART TO ANYONE WITHOUT THE PERMISSION OF ALPHA RADIO PRODUCTS LLC.	PROJECT NO. 9500	ALPHA RADIO PRODUCTS LLC 6185 ARAPAHOE RD. BOULDER, COLORADO 80303 PHONE: (303) 473-9232 FAX: (303) 473-9660		
	ENGINEER: G. HANDEMAN DESIGNER: B. FOCKEN DATE: 07/25/08 DRAFT DATE: 07/25/08		TITLE: SCH, 9500, MAIN CONTROLLER PCB	
PROPRIETARY NOTICE: THIS DOCUMENT AND DATA DISCLOSED HEREIN AND HEREWITH IS NOT TO BE REPRODUCED, COPIED, OR DISCLOSED IN WHOLE OR ANY PART TO ANYONE WITHOUT THE PERMISSION OF ALPHA RADIO PRODUCTS LLC.	DRAWING FILE: BCX-X421_REV_A_SCH	SIZE C	DRAWING # BCX-X421 BIAS	REV. A
COMPONENT TYPE - ELECTRICAL CATEGORY - CUSTOM DESIGNATION - NONE	PADS POWERLOGIC DRAWING	SCALE	SHEET 5 OF 8	

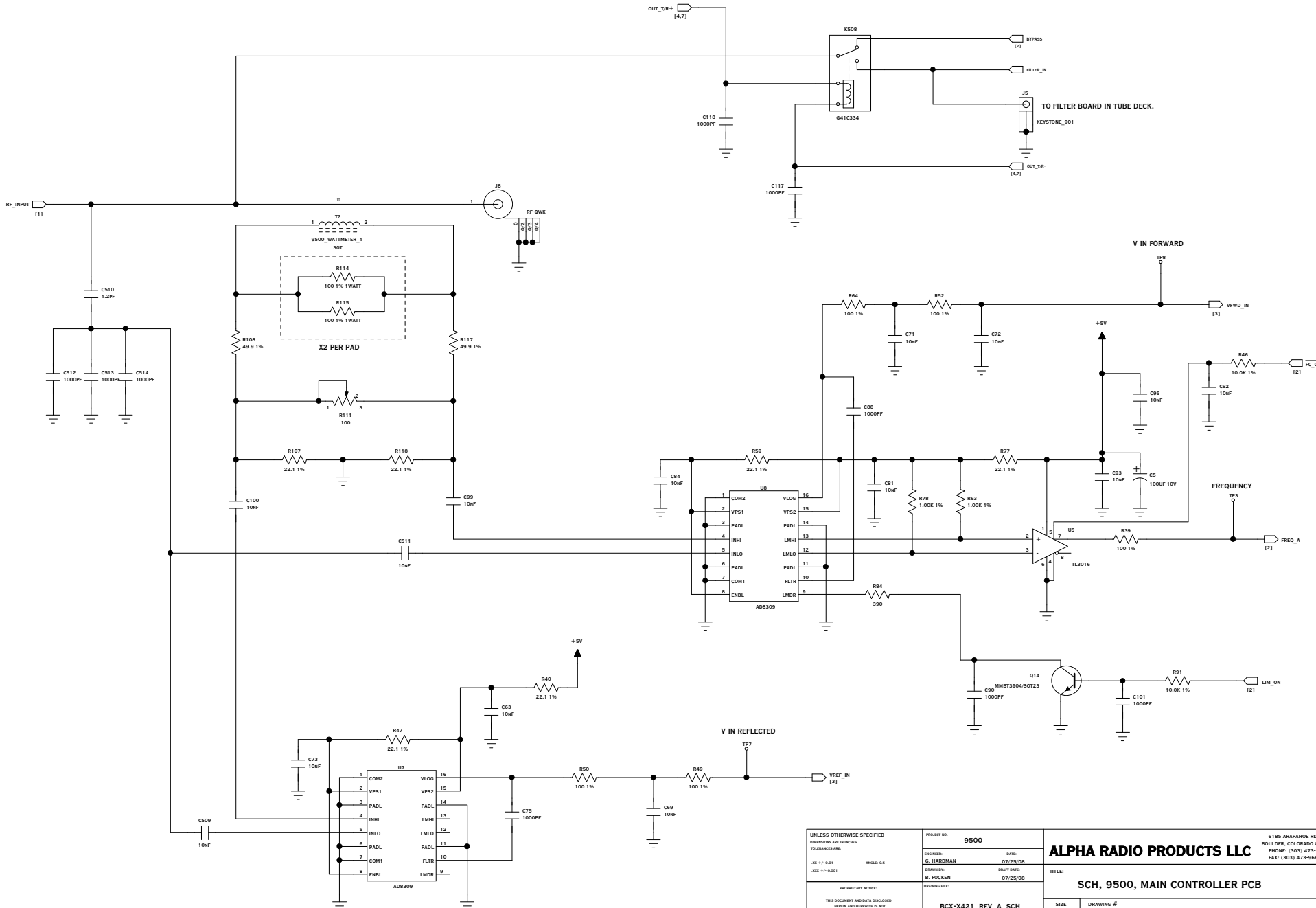

UNLESS OTHERWISE SPECIFIED DIMENSIONS ARE IN INCHES TOLERANCES ARE: .XX +/- 0.01 ANGLE: 0.5 .XXX +/- 0.001 PROPRIETARY NOTICE: THIS DOCUMENT AND DATA DISCLOSED HEREIN AND HEREWITH IS NOT TO BE REPRODUCED, COPIED, OR DISCLOSED IN WHOLE OR ANY PART TO ANYONE WITHOUT THE PERMISSION OF ALPHA RADIO PRODUCTS LLC.	PROJECT NO. 9500 ENGINEER: G. HARMAN DRAWN BY: B. FOCKEN DATE: 07/25/08 DRAW DATE: 07/25/08	ALPHA RADIO PRODUCTS LLC 6185 ARAPAHOE RD. BOULDER, COLORADO 80303 PHONE: (303) 473-9232 FAX: (303) 473-9660
	DRAWING FILE: BCX-X421_REV_A_SCH PADS POWERBOARD DRAWING	
COMPONENT TYPE - ELECTRICAL CATEGORY - CUSTOM DESIGNATION - NONE	SIZE C DRAWING # BCX-X421 INPUT WATT METER	REV. A SHEET 6 OF 8

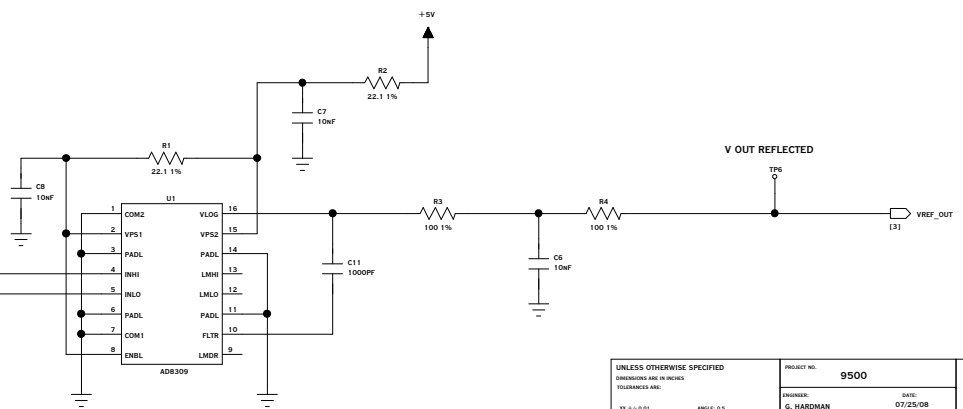
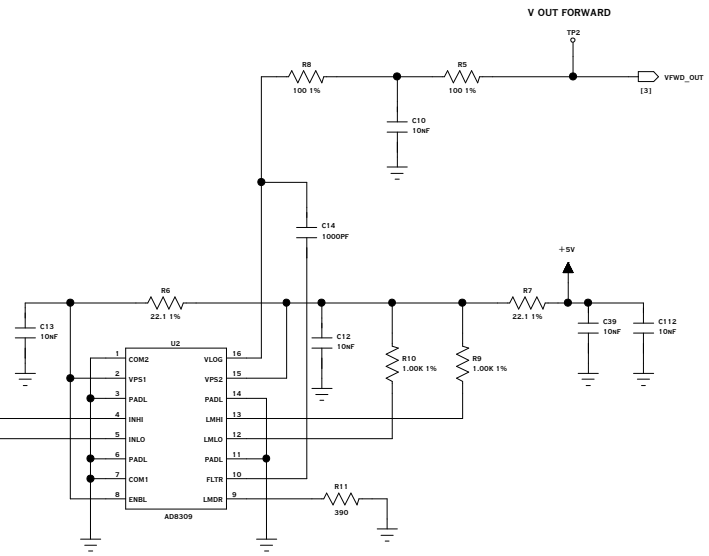
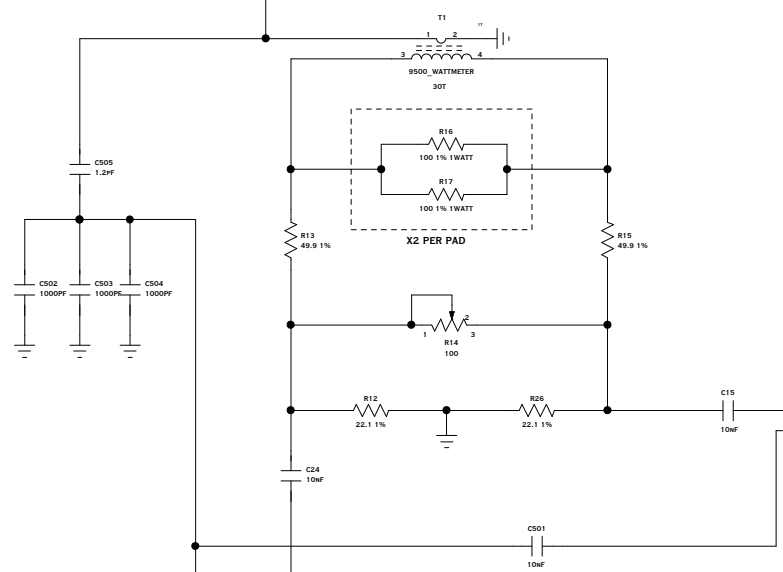
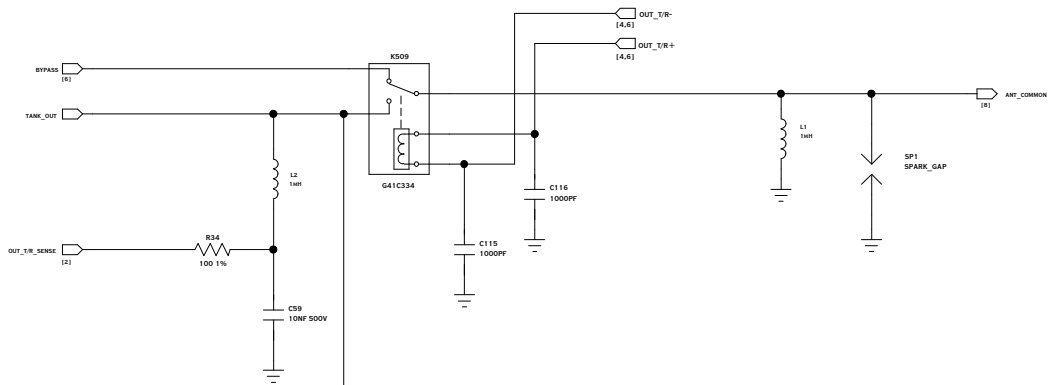

UNLESS OTHERWISE SPECIFIED DIMENSIONS ARE IN INCHES TOLERANCES ARE: XX +/- 0.01 ANGLE: 0.5 X.XX +/- 0.001		PROJECT NO. 9500	6185 ARAPAHOE RD. BOULDER, COLORADO 80303 PHONE: (303) 473-9232 FAX: (303) 473-9660
PROPRIETARY NOTICE: THIS DOCUMENT AND DATA DISCLOSED HEREIN AND HEREWITH IS NOT TO BE REPRODUCED, COPIED, OR DISCLOSED IN WHOLE OR ANY PART TO ANYONE WITHOUT THE PERMISSION OF ALPHA RADIO PRODUCTS LLC.		ENGINEER: G. HARMAN DRAWN BY: B. FOCKEN	DATE: 07/25/08 DRAWN DATE: 07/25/08
DRAWING FILE: BCX-X421_REV_A_SCH		TITLE: SCH, 9500, MAIN CONTROLLER PCB	
PAGE NUMBER/NO. OF PAGES: 1/1		SIZE C	DRAWING # BCX-X421 OUTPUT WATT METER
SCALE		REV. A	
SHEET 7 OF 8			

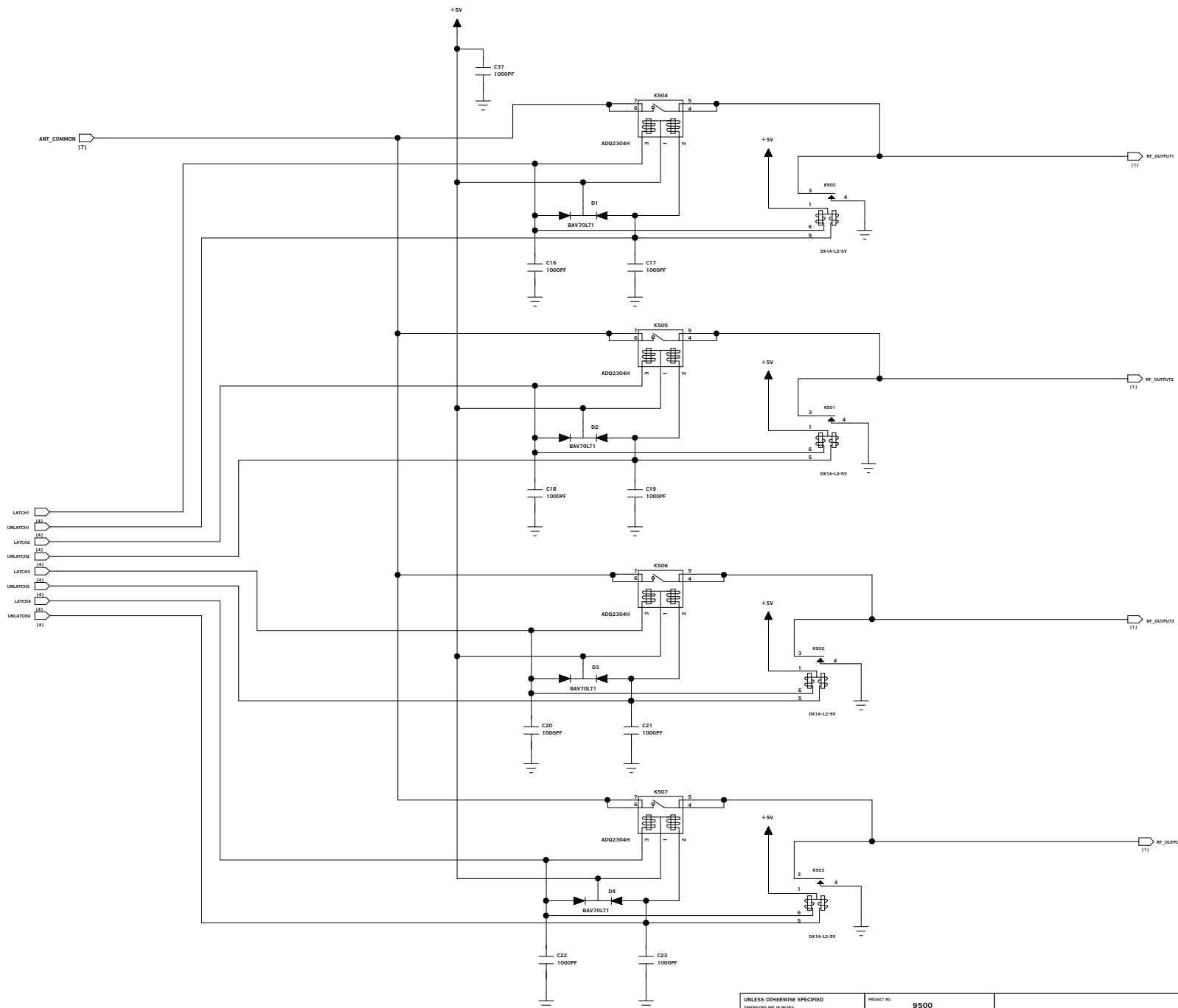

UNLESS OTHERWISE SPECIFIED DIMENSIONS ARE IN INCHES TOLERANCES ARE: .XX +/- 0.01 ANGLE: 0.5 .001 +/- 0.001	PROJECT NO. 9500	ALPHA RADIO PRODUCTS LLC 6185 ARAPAHOE RD. BOULDER, COLORADO 80303 PHONE: (303) 473-9232 FAX: (303) 473-9660
	ENGINEER: S. HARMAN DATE: 07/25/08 DRAWN BY: B. FOCKEN DATE: 07/25/08	
PROPRIETARY NOTICE: THIS DOCUMENT AND DATA DISCLOSED HEREIN AND HEREWITH IS NOT TO BE REPRODUCED, COPIED, OR DISCLOSED IN WHOLE OR ANY PART TO ANYONE WITHOUT THE PERMISSION OF ALPHA RADIO PRODUCTS LLC.	DRAWING FILE: BCX-X421_REV_A.SCH	SCH, 9500, MAIN CONTROLLER PCB
COMPONENT TYPE - ELECTRICAL CATEGORY - 030104 DESIGNATION - NONE	PADS POWERLOGIC DRAWING	SIZE C DRAWING # BCX-X421 REV. A
SCALE		SHEET 8 OF 8

REVISION HISTORY					
REV	ECO NO.	DESCRIPTION	CHANGED BY & DATE	CHECKED BY & DATE	EFFECTIVITY DATE
1.1		INITIAL RELEASE	BWF 09/25/05	GEH 09/25/05	09/25/05
1.2		VALUE CHANGES AND WIRES	BWF 04/05/06	GEH 04/05/06	04/05/06
1.3		VALUE CHANGES AND WIRES	BWF 07/15/06	GEH 07/15/06	07/15/06
2		ADD POWER SUPPLY	BWF 08/01/06	GEH 08/01/06	08/01/06

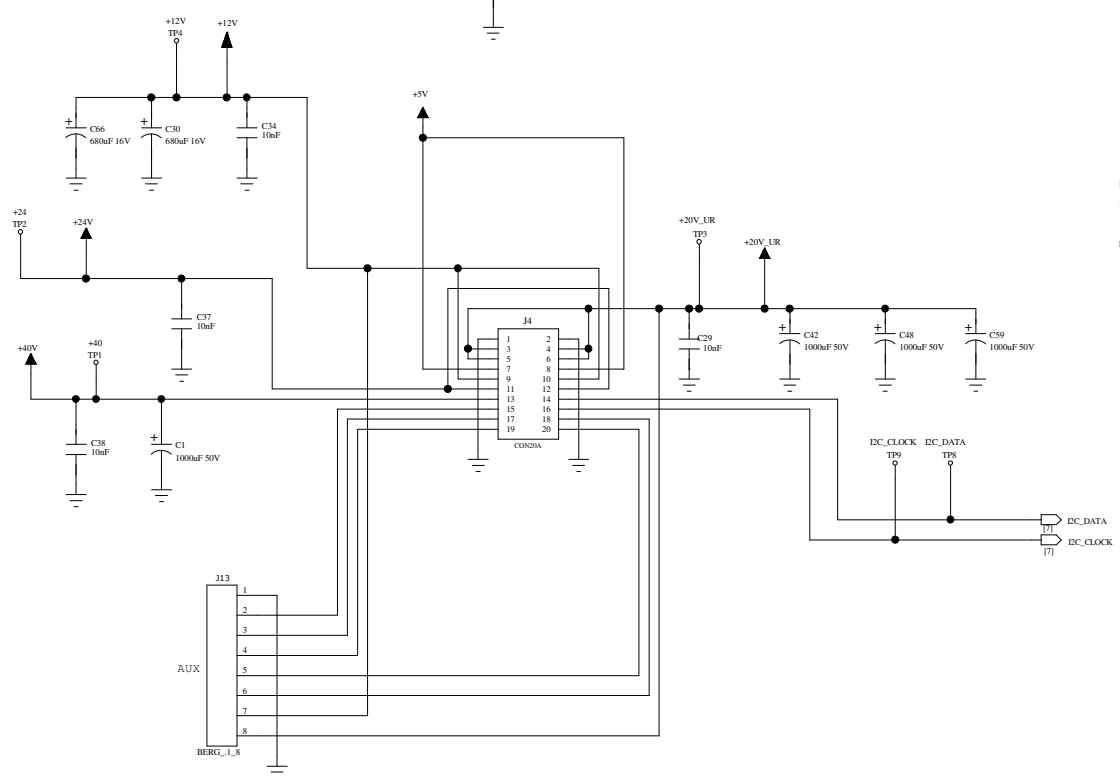
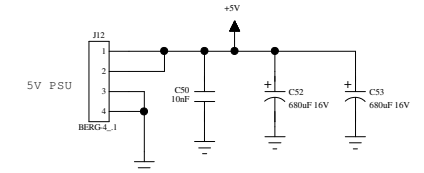
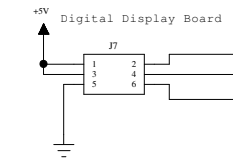
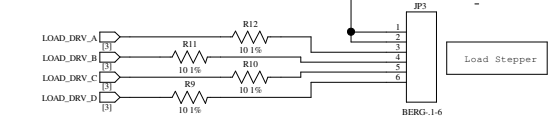
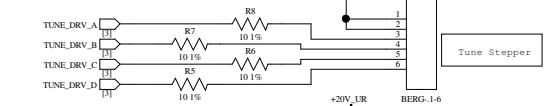
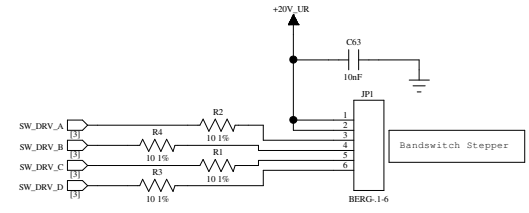
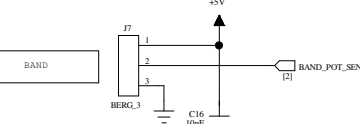
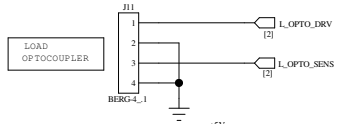
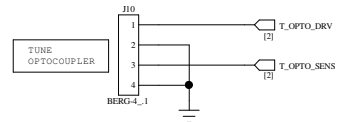

UNLESS OTHERWISE SPECIFIED DIMENSIONS ARE IN INCHES TOLERANCES ARE: .XX +/- 0.01 ANGLE: 0.5 .XXX +/- 0.001	PROJECT NO. 9500	6185 ARAPAHOE RD. BOULDER, COLORADO 80303 PHONE: (303) 473-9232 FAX: (303) 473-9660
	ENGINEER: C. HARMANN DATE: 08/20/06 DRAWN BY: B. FOCKEN DRAFT DATE: 08/20/06	
PROPRIETARY NOTICE: THIS DOCUMENT AND DATA DISCLOSED HEREIN AND HEREWITH IS NOT TO BE REPRODUCED, COPIED, OR DISCLOSED IN WHOLE OR ANY PART TO ANYONE WITHOUT THE PERMISSION OF ALPHA RADIO PRODUCTS LLC.	TITLE: SCHM, 9500, FRONT PANEL PCB	SIZE: C DRAWING #: BCX-X422
COMPONENT TYPE = ELECTRICAL CATEGORICAL DESIGNATION = CUSTOM DESIGNATION = NONE	PROJECT NO. 9500	SCALE
	PAGE POWERLOGIC DRAWING	SHEET 1 OF 7

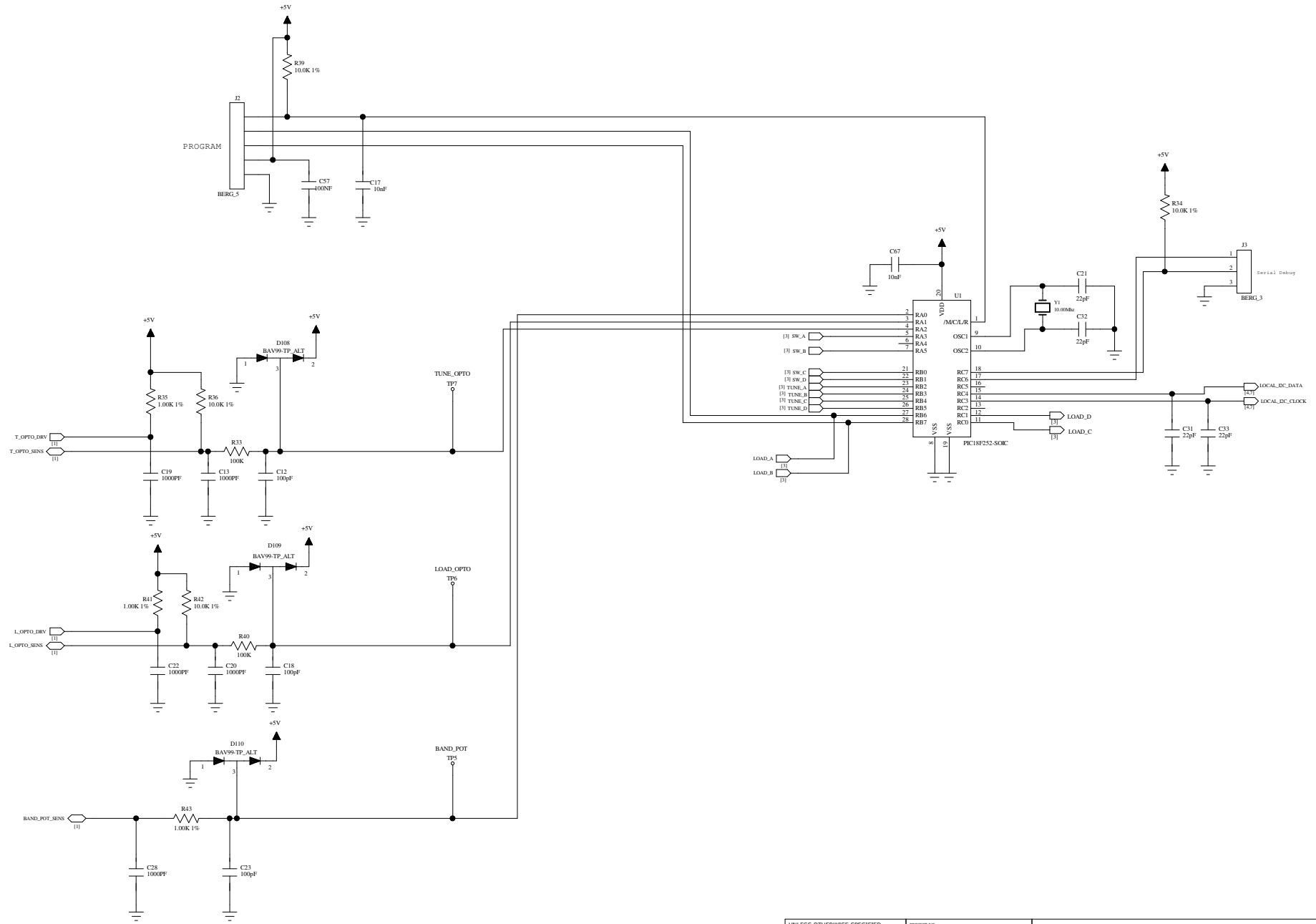

UNLESS OTHERWISE SPECIFIED DIMENSIONS ARE IN INCHES TOLERANCES ARE: .XX +/- 0.01 ANGLE: 0.5 (.XX +/- 0.00)	PROJECT NO. 9500	ALPHA RADIO PRODUCTS LLC 6185 ARAPAHOE RD. BOULDER, COLORADO 80303 PHONE: (303) 473-9232 FAX: (303) 473-9660
	ENGINEER: CG HARMANN	
PROPRIETARY NOTICE: THIS DOCUMENT AND DATA DISCLOSED HEREIN AND HEREWITH IS NOT TO BE REPRODUCED, COPIED, OR DISCLOSED IN WHOLE OR ANY PART TO ANYONE WITHOUT THE PERMISSION OF ALPHA RADIO PRODUCTS LLC.	DRAWN BY: B. HOCKEN	DRAFT DATE: 08/28/18
COMPONENT TYPE = ELECTRICAL CATEGORY = CUSTOM DESIGNATION = NONE	DRAWING FILE: BCX-X422_REV_A_SCH	TITLE: SCH, 9500, FRONT PANEL PCB
PAGE POWERBLOCK DRAWING	SIZE C	DRAWING # BCX-X422
SCALE	REV. A	SHEET 2 OF 7

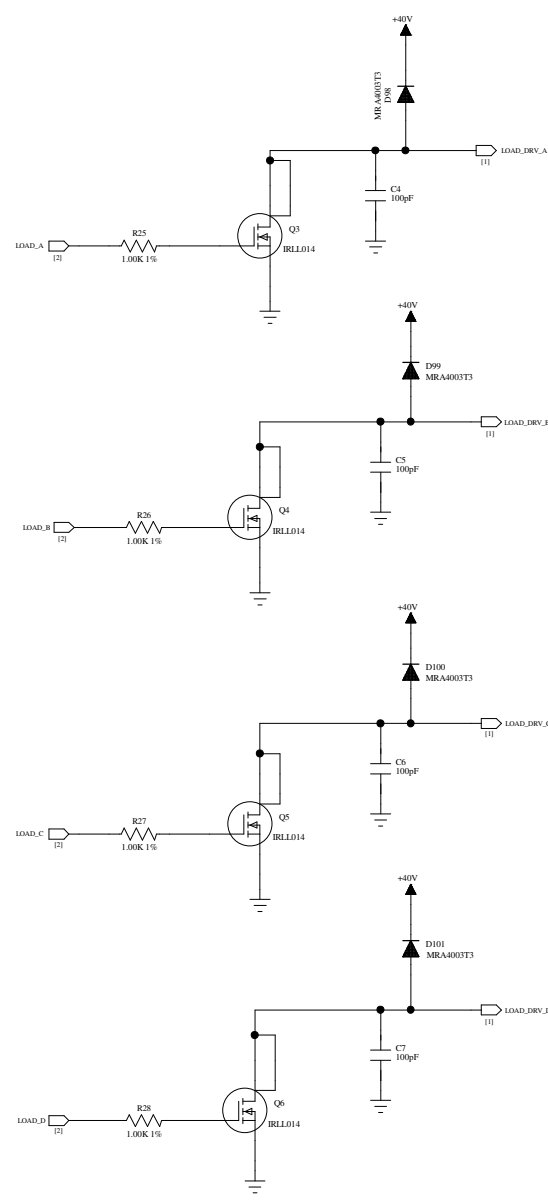
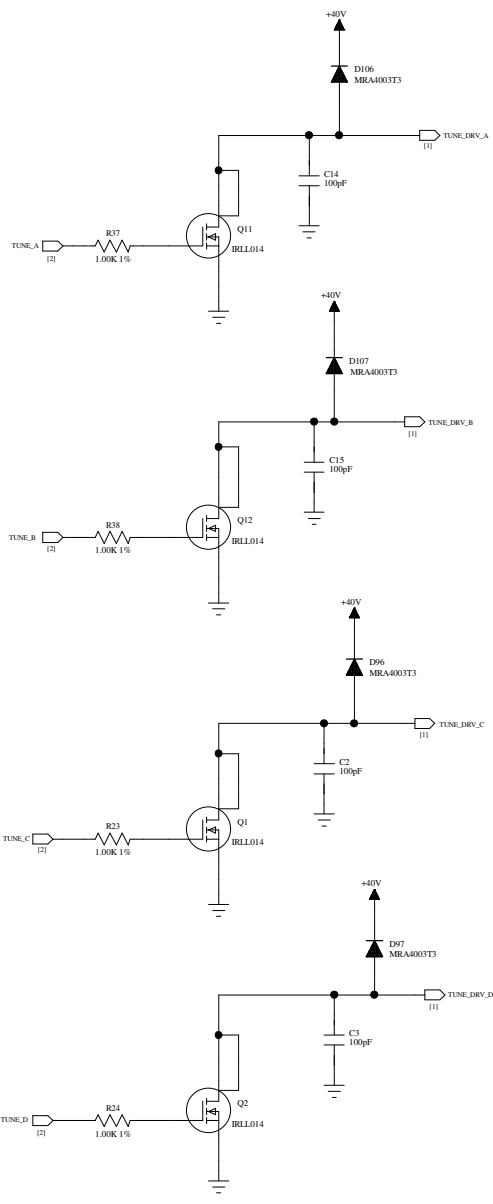
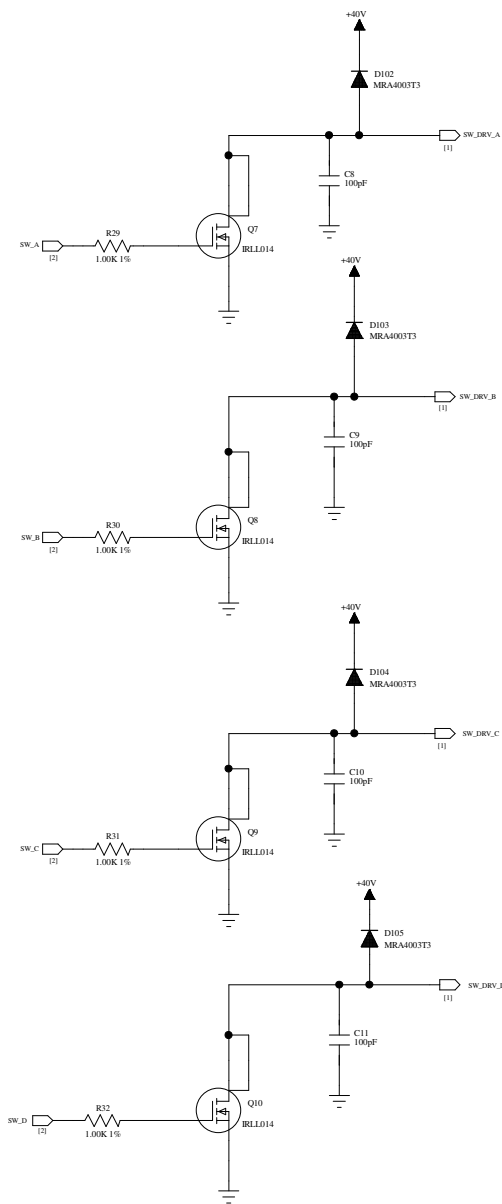

UNLESS OTHERWISE SPECIFIED DIMENSIONS ARE IN INCHES TOLERANCES ARE: XX +/- 0.01 ANGLE: 0.5 XXX +/- 0.001	PROJECT NO. 9500	ALPHA RADIO PRODUCTS LLC 6185 ARAPAHOE RD. BOULDER, COLORADO 80303 PHONE: (303) 473-9232 FAX: (303) 473-9660
	ENGINEER: C. HARDMANN DATE: 08/20/08	
PROPRIETARY NOTICE: THIS DOCUMENT AND DATA DISCLOSED HEREIN AND HEREWITH IS NOT TO BE REPRODUCED, COPIED, OR DISCLOSED IN WHOLE OR ANY PART TO ANYONE WITHOUT THE PERMISSION OF ALPHA RADIO PRODUCTS LLC.	DRAWN BY: B. FOCKEN DATE: 08/20/08	TITLE: SCH, 9500, FRONT PANEL PCB
COMPONENT TYPE = ELECTRICAL CATEGORY = CUSTOM DESIGNATION = NONE	DRAWING FILE: BCX-X422_REV_A_SCH	SIZE C DRAWING # BCX-X422
	PAGE POWERBLOCK DRAWING	SCALE
		REV. A
		SHEET 3 OF 7

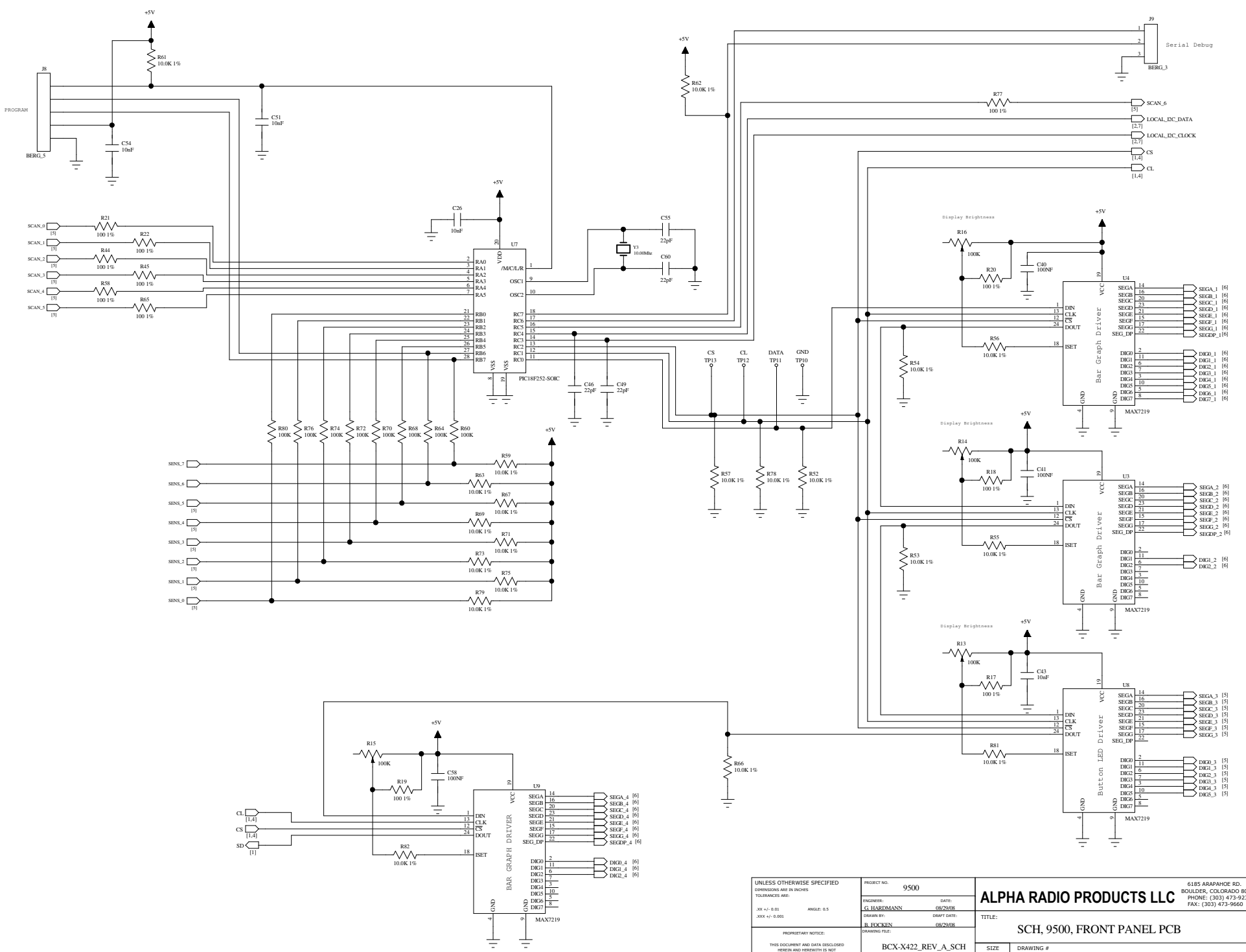

UNLESS OTHERWISE SPECIFIED DIMENSIONS ARE IN INCHES TOLERANCES ARE: .XX +/- 0.01 ANGLE: 0.5 .XXX +/- 0.003		PROJECT NO. 9500 ENGINEER: G. HARMANN DRAWN BY: B. HOCKEN DATE: 08/20/08 DRAFT DATE: 08/20/08		6185 ARAPAHOE RD. BOULDER, COLORADO 80303 PHONE: (303) 473-9232 FAX: (303) 473-9660	
PROPRIETARY NOTICE: THIS DOCUMENT AND DATA DISCLOSED HEREIN AND HEREWITNESS IS NOT TO BE REPRODUCED, COPIED, OR DISCLOSED IN WHOLE OR PART TO ANYONE WITHOUT THE PERMISSION OF ALPHA RADIO PRODUCTS LLC.		TITLE: SCH, 9500, FRONT PANEL PCB		REV. A	
COMPONENT TYPE = ELECTRICAL CATEGORY = CUSTOM DESIGNATION = NONE		DRAWING FILE: BCX-X422_REV_A_SCH		DRAWING # BCX-X422	
PADS POWERBOLE DRAWING		SCALE		SHEET 4 OF 7	

6

5

4

3

2

1

D

D

C

C

B

B

A

A

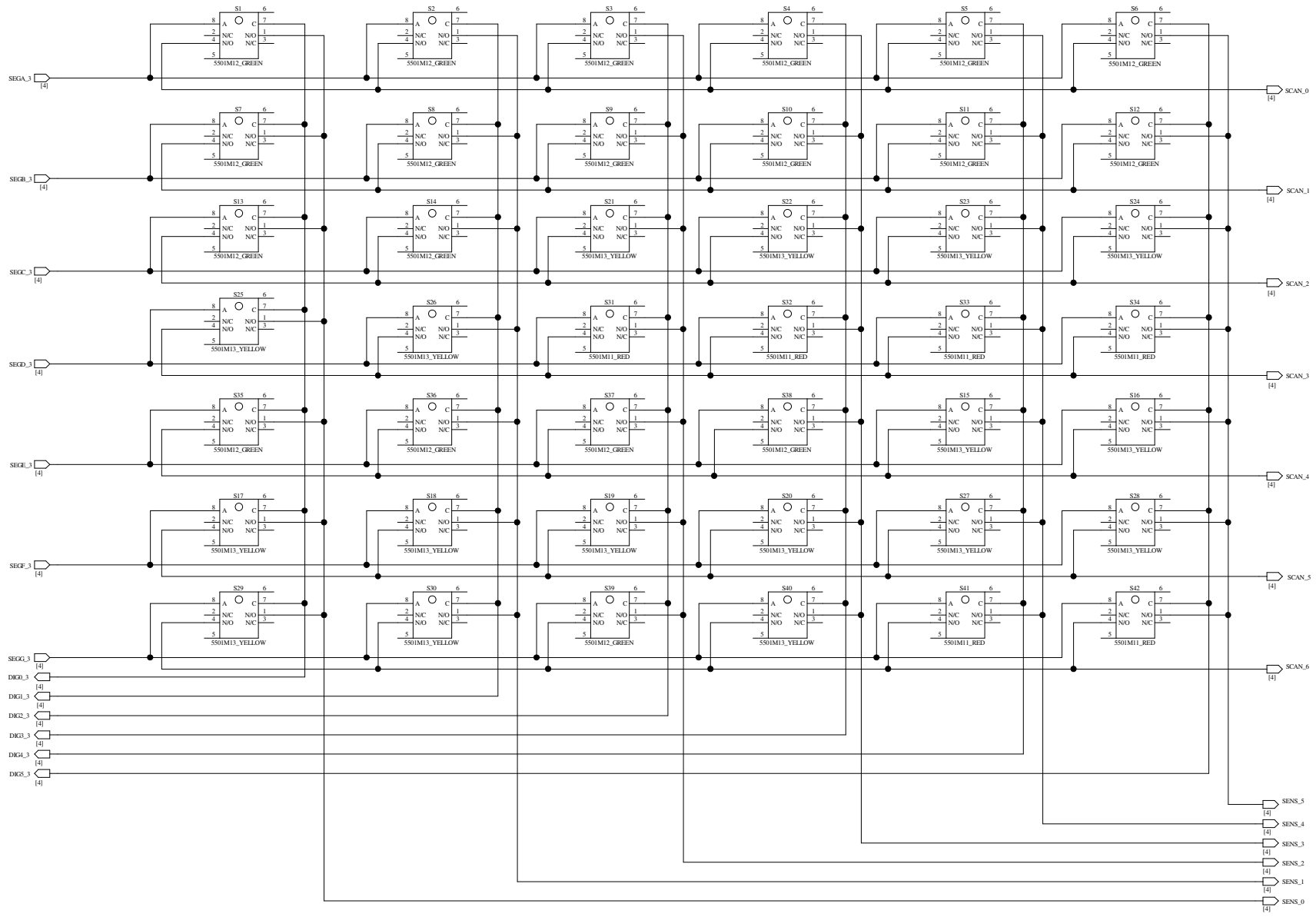

UNLESS OTHERWISE SPECIFIED DIMENSIONS ARE IN INCHES TOLERANCES ARE: XX +/- 0.01 ANGLE: 0.5 XXX +/- 0.001		PROJECT NO. 9500 ENGINEER: LG HARDMANN DATE: 08/20/08 DRAWN BY: B. FOCKEN DATE: 08/20/08	6185 ARAPAHOE RD. BOULDER, COLORADO 80303 PHONE: (303) 473-9232 FAX: (303) 473-9660
PROPRIETARY NOTICE: THIS DOCUMENT AND DATA DISCLOSED HEREIN AND HEREWITH IS NOT TO BE REPRODUCED, COPIED, OR DISCLOSED IN WHOLE OR ANY PART TO ANYONE WITHOUT THE PERMISSION OF ALPHA RADIO PRODUCTS LLC.		TITLE: SCH, 9500, FRONT PANEL PCB DRAWING FILE: BCX-X422_REV_A_SCH	SCALE: 1:1
COMPONENT TYPE = ELECTRICAL CATEGORY = CUSTOM DESIGNATION = NONE	SIZE C	DRAWING # BCX-X422	REV. A
PAGES POWERLOGIC DRAWING		SHEET 5 OF 7	

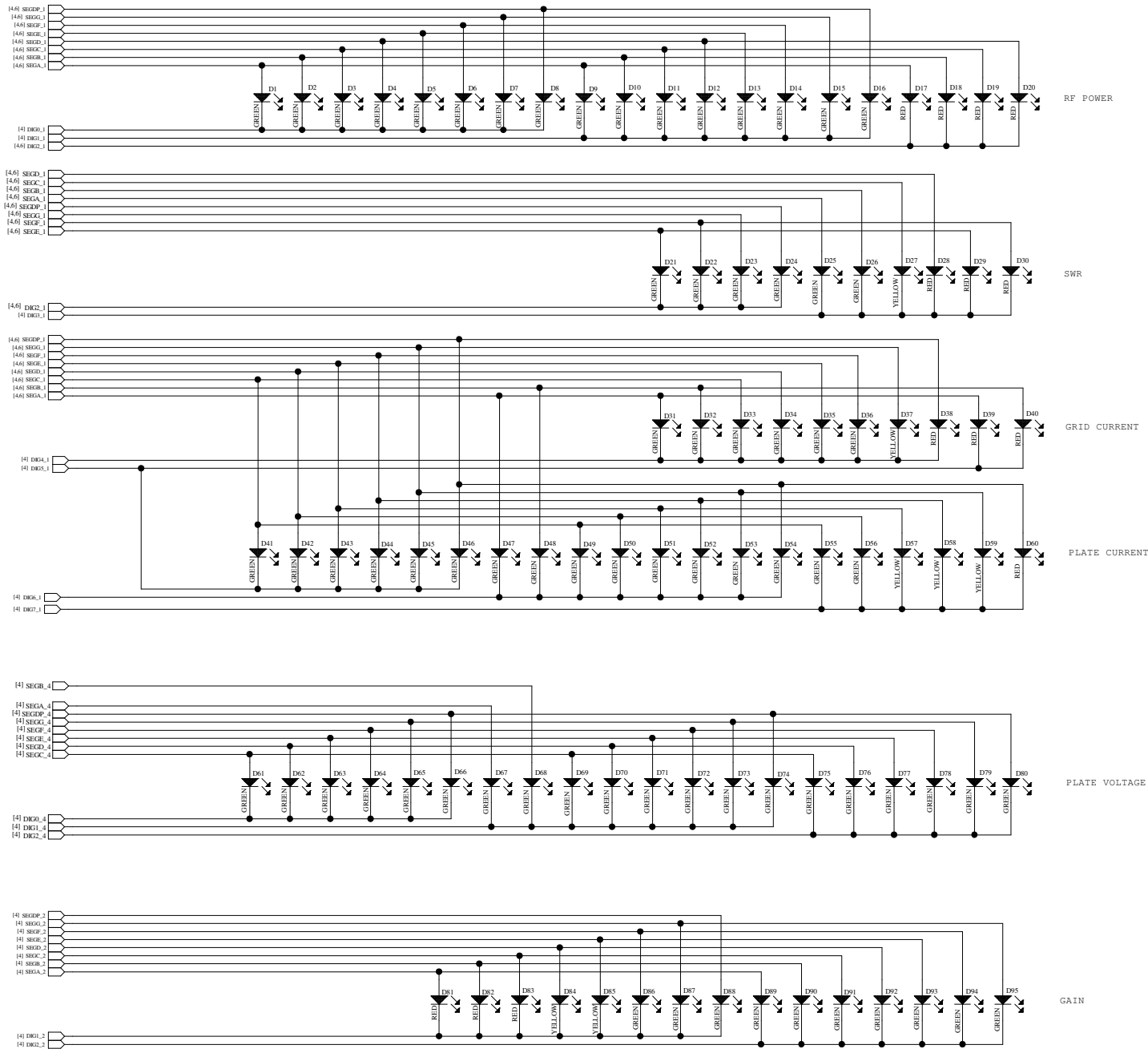

UNLESS OTHERWISE SPECIFIED DIMENSIONS ARE IN INCHES TOLERANCES ARE:		PROJECT NO. 9500
.XX +/- 0.01	ANGLE: 0.5	ENGINEER: LG HARMANN
.XXX +/- 0.001		DATE: 08/20/08
PROPRIETARY NOTICE: THIS DOCUMENT AND DATA DISCLOSED HEREIN AND HEREWITH IS NOT TO BE REPRODUCED, COPIED, OR DISCLOSED IN WHOLE OR ANY PART TO ANYONE WITHOUT THE PERMISSION OF ALPHA RADIO PRODUCTS LLC.		DRAWN BY: B. FOCKEN
DRAWING FILE: BCX-X422_REV_A_SCH		DATE: 08/20/08
PAGES POWERLOGIC DRAWING		TITLE: SCHEMATIC,FRONT PANEL ALPHA 9500

ALPHA RADIO PRODUCTS LLC 6185 ARAPAHOE RD. BOULDER, COLORADO 80303 PHONE: (303) 473-9232 FAX: (303) 473-9660		
SIZE C	DRAWING # BCX-X422	REV. A
SCALE		SHEET 6 OF 7

COMPONENT TYPE = ELECTRICAL
CATEGORY = CUSTOM
DESIGNATION = NONE

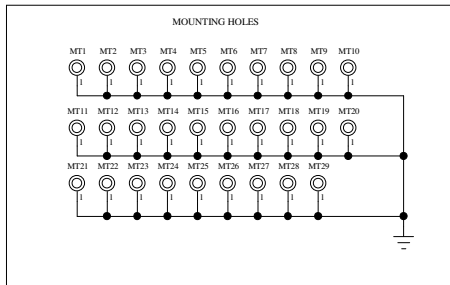
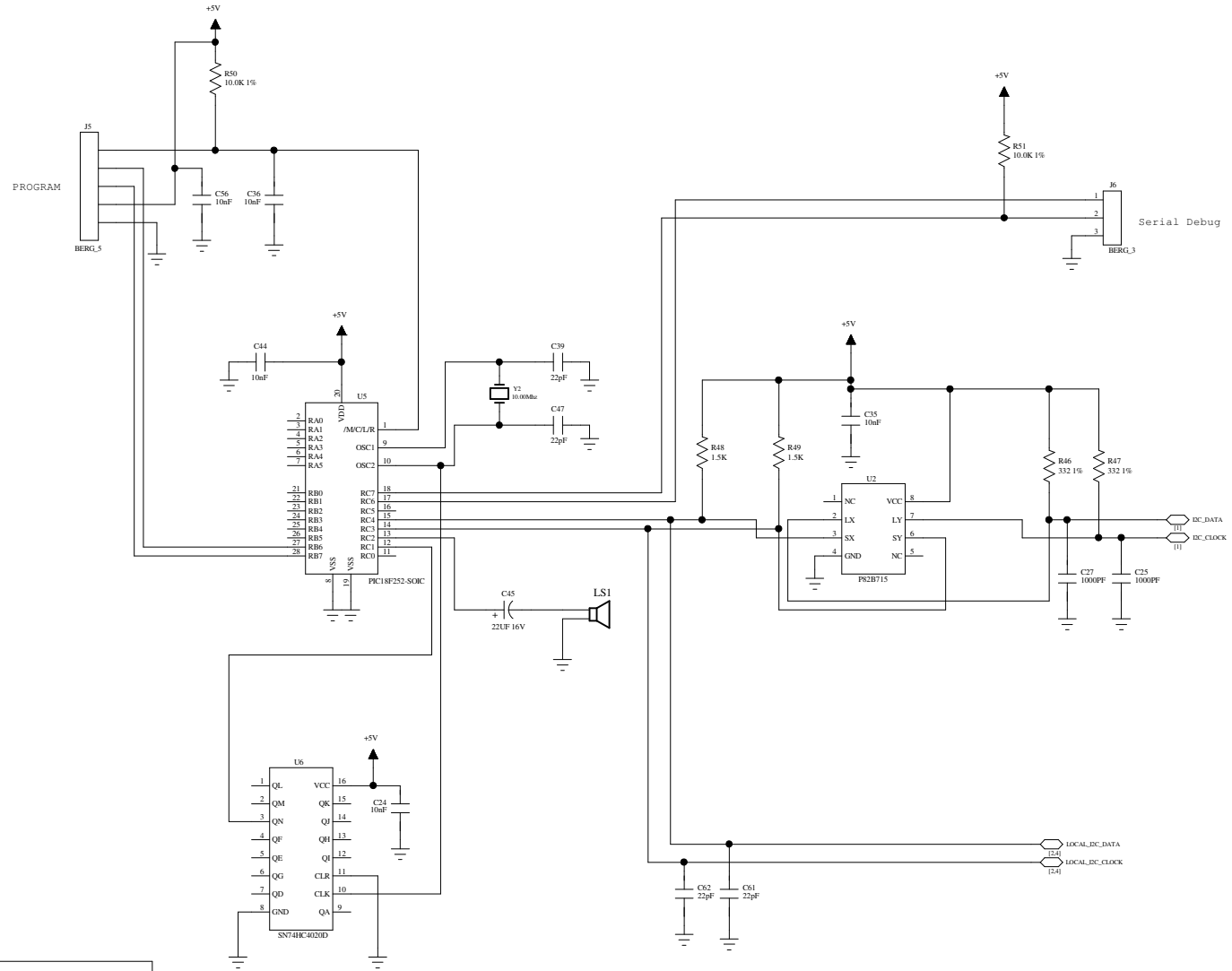

UNLESS OTHERWISE SPECIFIED DIMENSIONS ARE IN INCHES TOLERANCES ARE: .XX +/- 0.01 ANGLE: 0.5 (SEE 47-8.00)	PROJECT NO. 9500	6185 ARAPAHOE RD. BOULDER, COLORADO 80303 PHONE: (303) 473-9232 FAX: (303) 473-9660
	ENGINEER: G. HARDMANN DATE: 08/20/08	
PROPRIETARY NOTICE: THIS DOCUMENT AND DATA DISCLOSED HEREIN AND HEREWITH IS NOT TO BE REPRODUCED, COPIED, OR DISCLOSED IN WHOLE OR ANY PART TO ANYONE WITHOUT THE PERMISSION OF ALPHA RADIO PRODUCTS LLC.	DRAWING FILE: BCX-X422_REV_A_SCH	TITLE: SCH, 9500, FRONT PANEL PCB
COMPONENT TYPE = ELECTRICAL CONTROLLER = CUSTOM DESIGNATION = NONE	PAID POWERLOGIC DRAWING	SIZE C DRAWING # BCX-X422
	SCALE	REV. A
		SHEET 7 OF 7

6

5

4

3

2

1

REVISION HISTORY

REV	ECO NO.	DESCRIPTION	CHANGED BY & DATE	CHECKED BY & DATE	EFFECTIVITY DATE
1		INITIAL RELEASE	BWF 08/25/06	GEH 08/25/06	08/25/06
2		SWAP U4 PINS 6 AND 7.	BWF 12/02/06	GEH 12/02/06	12/02/06

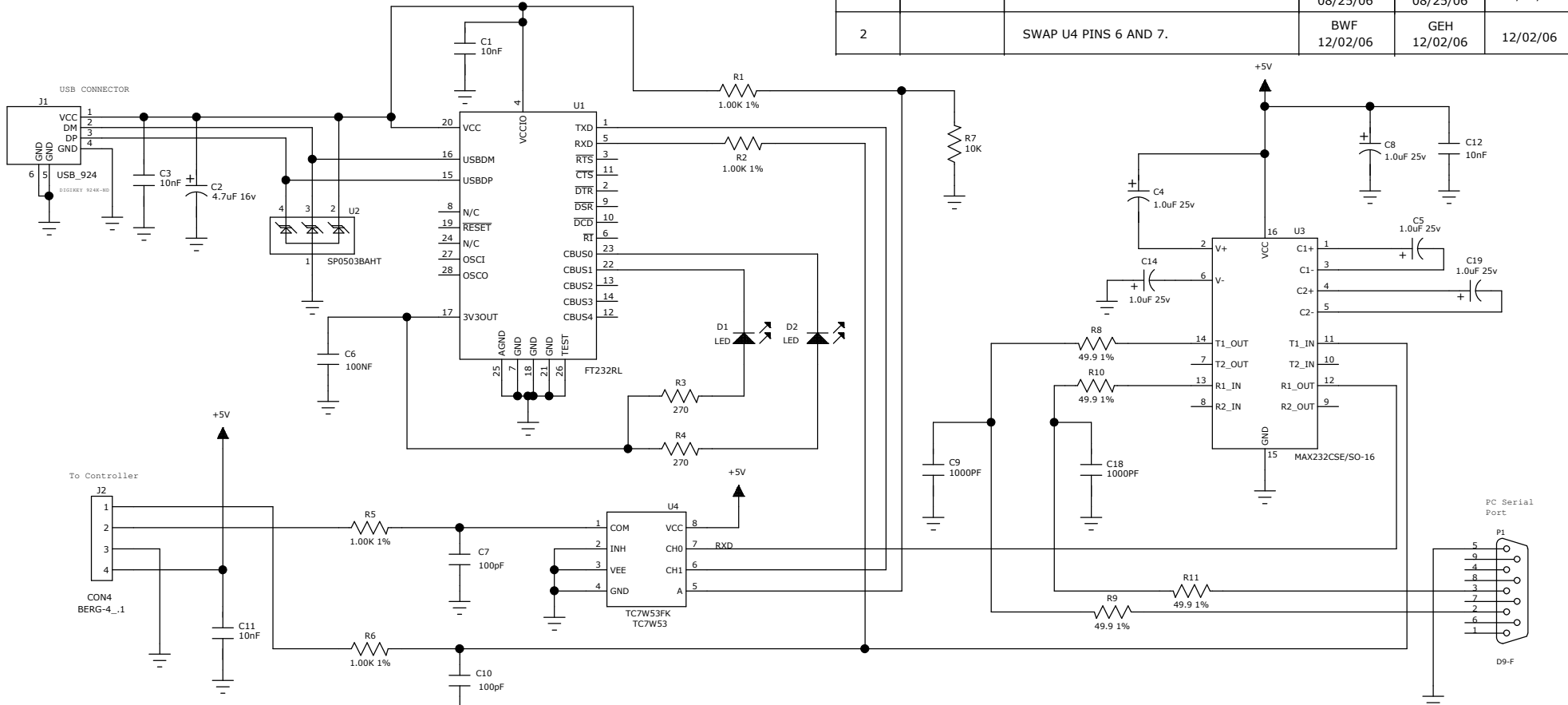

D

D

C

C

B

B

A

A

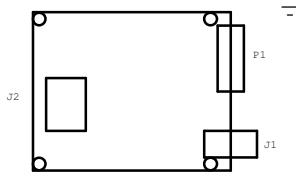
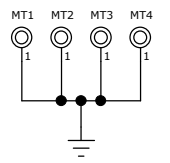

COMPONENT TYPE = ELECTRICAL
 CATEGORY = CUSTOM
 DESIGNATION = NONE

UNLESS OTHERWISE SPECIFIED
 DIMENSIONS ARE IN INCHES
 TOLERANCES ARE:
 .XX +/- 0.01 ANGLE: 0.5
 .XXX +/- 0.001

PROPRIETARY NOTICE:
 THIS DOCUMENT AND DATA DISCLOSED
 HEREIN AND HEREWITH IS NOT
 TO BE REPRODUCED, USED,
 OR DISCLOSED IN WHOLE OR
 ANY PART TO ANYONE WITHOUT
 THE PERMISSION OF ALPHA RADIO PRODUCTS LLC.

PROJECT NO. 9500
 ENGINEER: G. HARDMANN DATE: 12/02/06
 DRAWN BY: B. FOCKEN DRAFT DATE: 12/02/06

DRAWING FILE: BCX-X429_REV_2_SCH

PADS POWERLOGIC DRAWING

ALPHA RADIO PRODUCTS LLC
 6185 ARAPAHOE RD.
 BOULDER, COLORADO 80303
 PHONE: (303) 473-9232
 FAX: (303) 473-9660

TITLE: SCH, 9500/2100, USB BOARD

SIZE B	DRAWING # BCX-X429 USB	REV. 2
--------	------------------------	--------

SCALE SHEET 1 OF 1

REVISION HISTORY					
REV	ECO NO.	DESCRIPTION	CHANGED BY & DATE	CHECKED BY & DATE	EFFECTIVITY DATE
1		INITIAL RELEASE	BWF 10/07/06	GEH 10/07/06	10/07/06
2		ADD FAST ON AND RELAY CONNECTIONS.	BWF 11/09/06	GEH 11/09/06	11/09/06
2.1		ADD RCA CONNECTORS	BWF 11/09/06	GEH 11/09/06	11/09/06
3		CONNECT RELAYS TO 12V	BWF 12/01/06	GEH 12/01/06	12/01/06

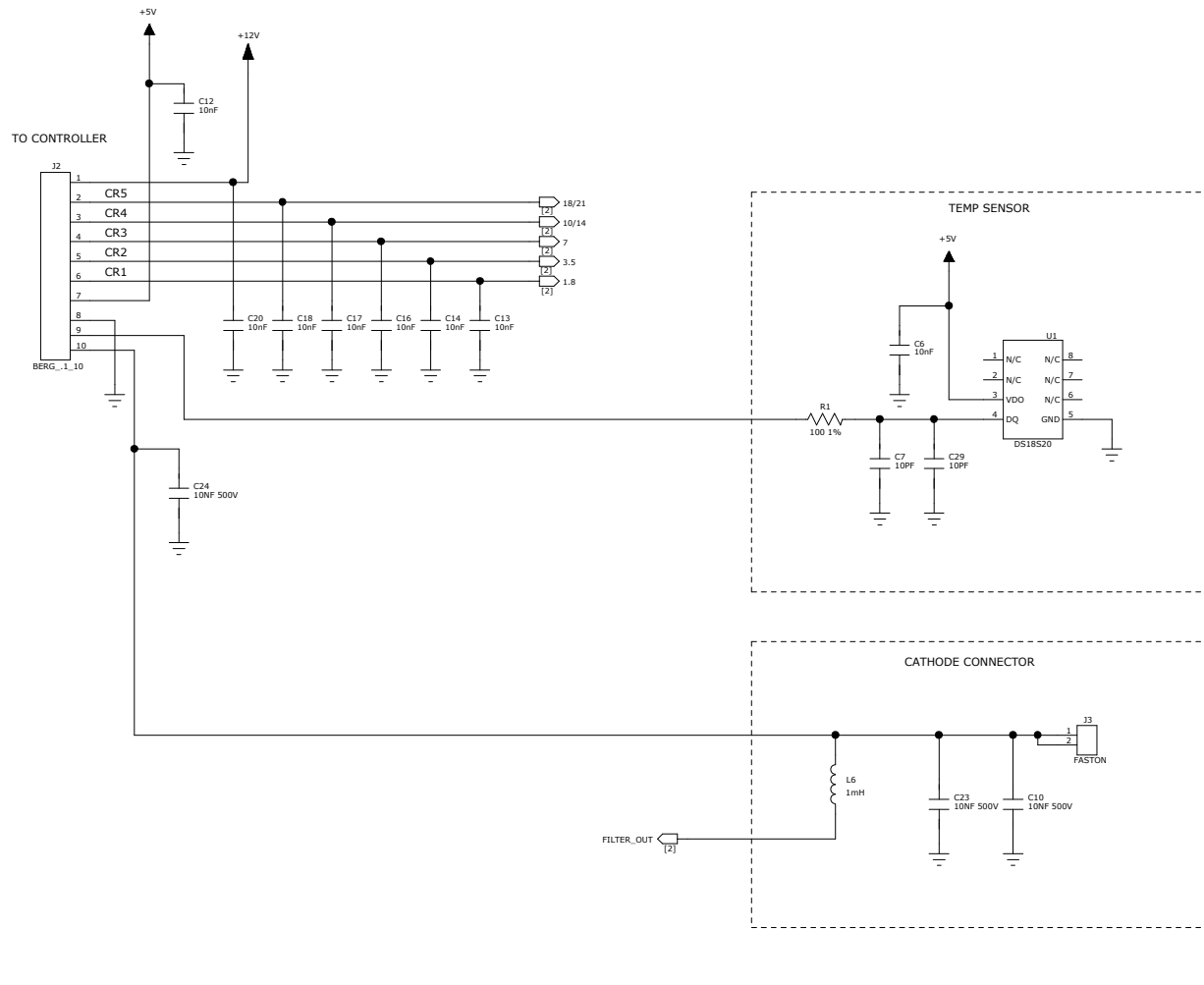

UNLESS OTHERWISE SPECIFIED DIMENSIONS ARE IN INCHES TOLERANCES ARE: .XX +/- 0.01 ANGLE: 0.5 .XXX +/- 0.001	PROJECT NO. 9500 ENGINEER: G. HARDMANN DATE: 12/01/06 DRAWN BY: B. FOCKEN DRAFT DATE: 12/01/06 DRAWING FILE:	ALPHA RADIO PRODUCTS LLC 6185 ARAPAHOE RD. BOULDER, COLORADO 80303 PHONE: (303) 473-9232 FAX: (303) 473-9660	
	PROPRIETARY NOTICE: THIS DOCUMENT AND DATA DISCLOSED HEREIN AND HEREWITH IS NOT TO BE REPRODUCED, COPIED, OR DISCLOSED IN WHOLE OR ANY PART TO ANYONE WITHOUT THE PERMISSION OF ALPHA RADIO PRODUCTS LLC.	PROJECT NO. 9500 DRAWING FILE: BCX-X430_REV_3_SCH PADS POWERBLOC DRAWING	TITLE: SCH, 9500, INPUT MATCH SIZE C DRAWING # BCX-X430 REV. 3 SCALE SHEET 1 OF 2

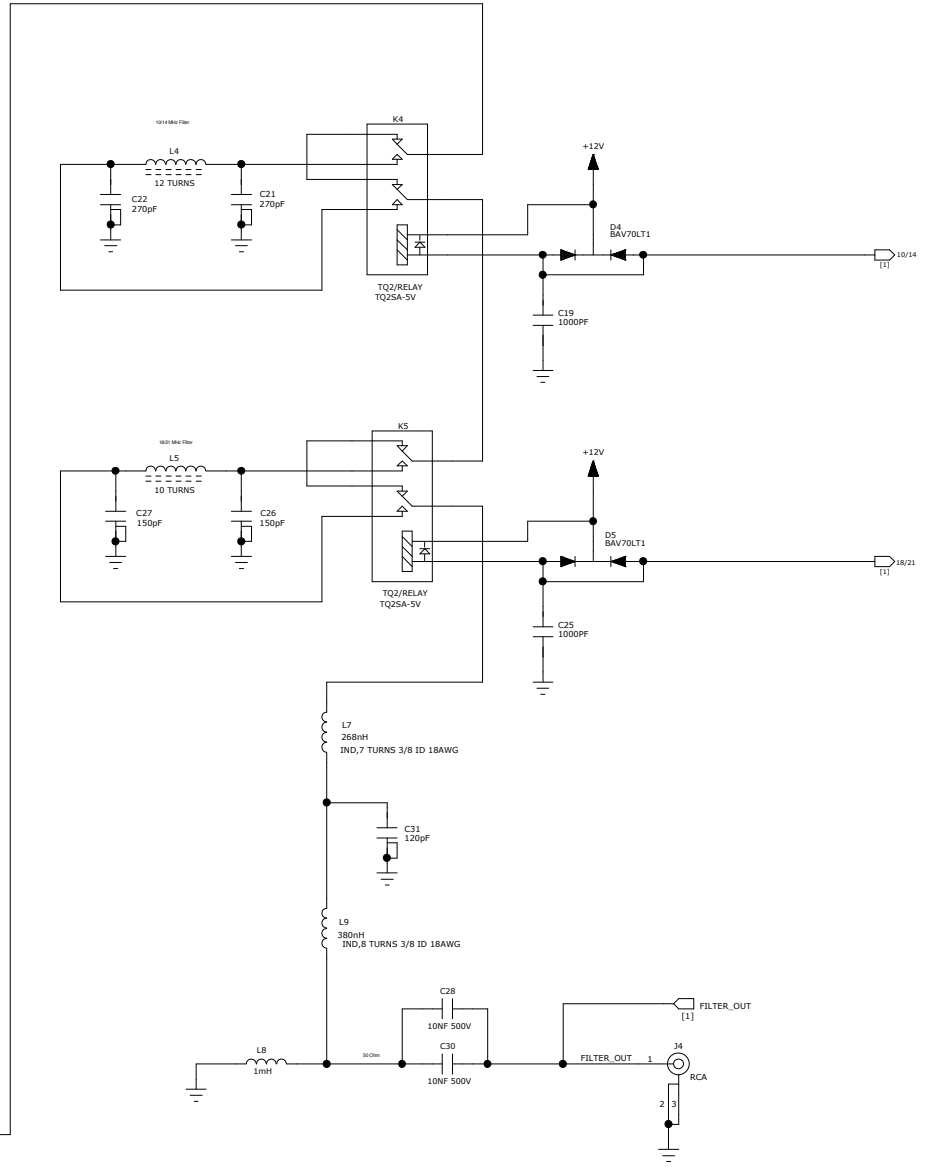
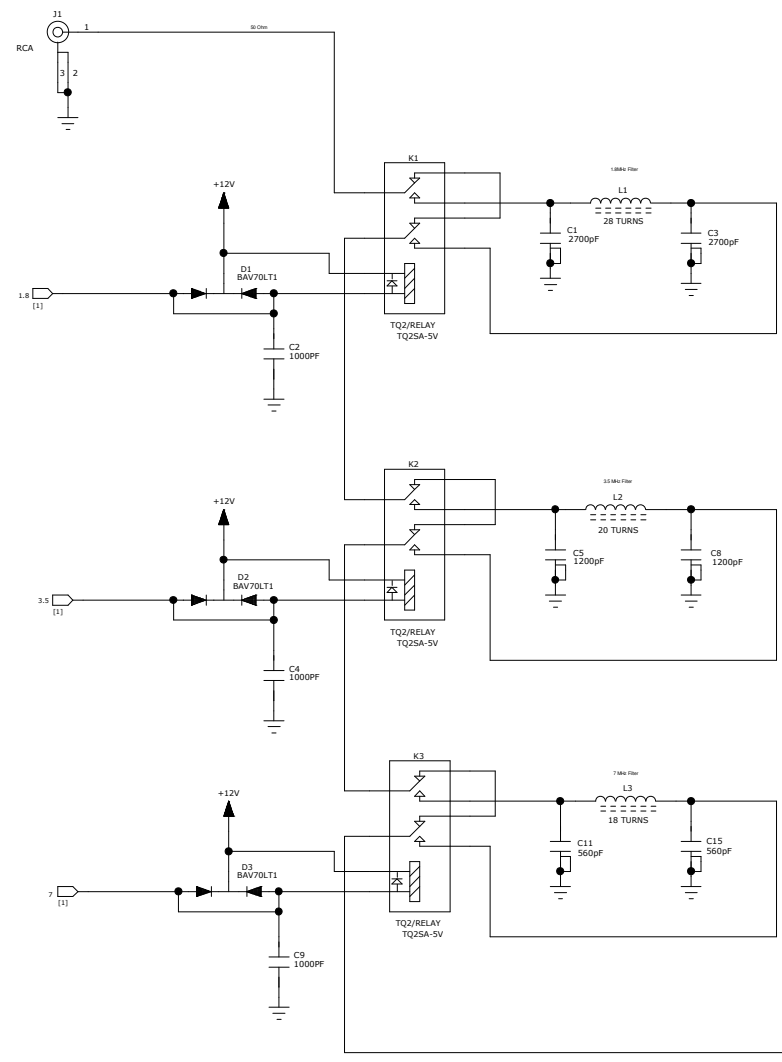

UNLESS OTHERWISE SPECIFIED DIMENSIONS ARE IN INCHES TOLERANCES ARE: .XX +/- .0.01 ANGLE: 0.5 .XXX +/- .0.005	PROJECT NO. 9500 ENGINEER: G. HARDMAN DRAWN BY: B. FOCKEN DRAWING FILE:	DATE: 11/20/06 DRAFT DATE: 11/20/06	6185 ARAPAHOE RD. BOULDER, COLORADO 80303 PHONE: (303) 473-9232 FAX: (303) 473-9660
	PROPRIETARY NOTICE: THIS DOCUMENT AND DATA DISCLOSED HEREIN AND HEREWITH IS NOT TO BE REPRODUCED, COPIED, OR DISCLOSED IN WHOLE OR ANY PART TO ANYONE WITHOUT THE PERMISSION OF ALPHA RADIO PRODUCTS LLC.		TITLE: SCH, 9500, INPUT MATCH
COMPONENT TYPE = ELECTRICAL CATEGORY = CUSTOM DESIGNATION = NONE	PROJECT NO. 9500 DRAWING FILE: BCX-X430_REV_3_SCH	TITLE: SCH, 9500, INPUT MATCH	SIZE C DRAWING # BCX-X430 REV. 3
PADS POWERBLOCK DRAWING		SCALE	SHEET 2 OF 2

6

5

4

3

2

1

REVISION HISTORY

REV	ECO NO.	DESCRIPTION	CHANGED BY & DATE	CHECKED BY & DATE	EFFECTIVITY DATE
1		INITIAL RELEASE	BWF 03/22/07	GEH 03/22/07	03/22/07

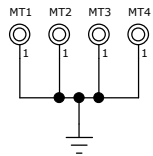
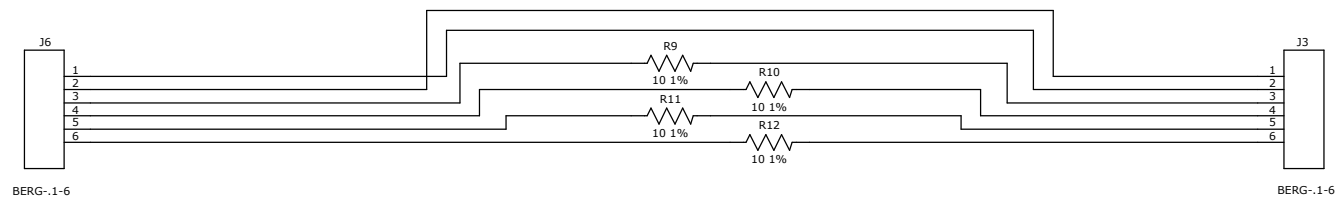
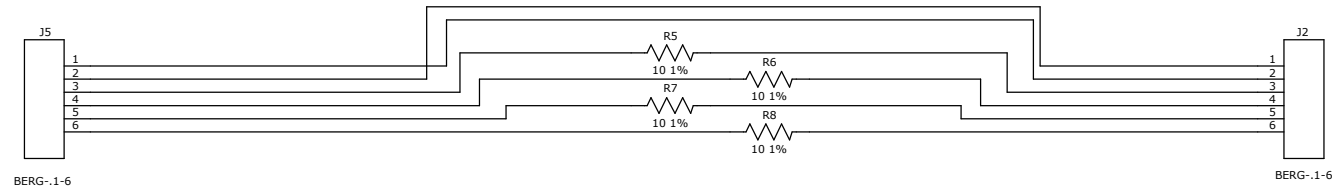
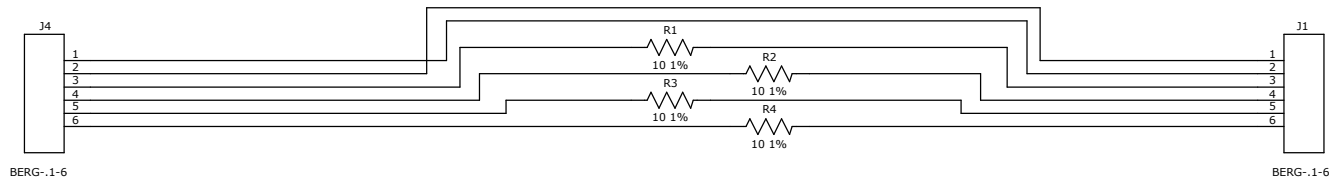

COMPONENT TYPE = ELECTRICAL
 CATEGORY = CUSTOM
 DESIGNATION = NONE

UNLESS OTHERWISE SPECIFIED
 DIMENSIONS ARE IN INCHES
 TOLERANCES ARE:
 .XX +/- 0.01 ANGLE: 0.5
 .XXX +/- 0.001

PROPRIETARY NOTICE:
 THIS DOCUMENT AND DATA DISCLOSED
 HEREIN AND HEREWITH IS NOT
 TO BE REPRODUCED, USED,
 OR DISCLOSED IN WHOLE OR
 ANY PART TO ANYONE WITHOUT
 THE PERMISSION OF ALPHA RADIO PRODUCTS LLC.

PROJECT NO. 9500
 ENGINEER: G. HARDMANN DATE: 03/22/07
 DRAWN BY: B. FOCKEN DRAFT DATE: 03/22/07

DRAWING FILE:
 BCX-X431_REV_1_SCH

PADS POWERLOGIC DRAWING

ALPHA RADIO PRODUCTS LLC
 6185 ARAPAHOE RD.
 BOULDER, COLORADO 80303
 PHONE: (303) 473-9232
 FAX: (303) 473-9660

TITLE:
 SCH, 9500, STEPPER RESISTOR

SIZE B DRAWING # BCX-X431 REV. 1

SCALE SHEET 1 OF 1

1

2

3

4

REVISION HISTORY					
REV	ECO NO.	DESCRIPTION	CHANGED BY & DATE	CHECKED BY & DATE	EFFECTIVITY DATE

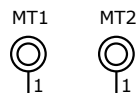
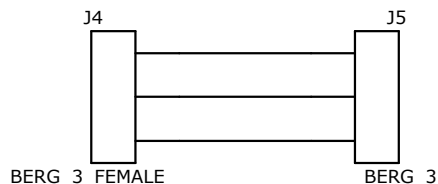
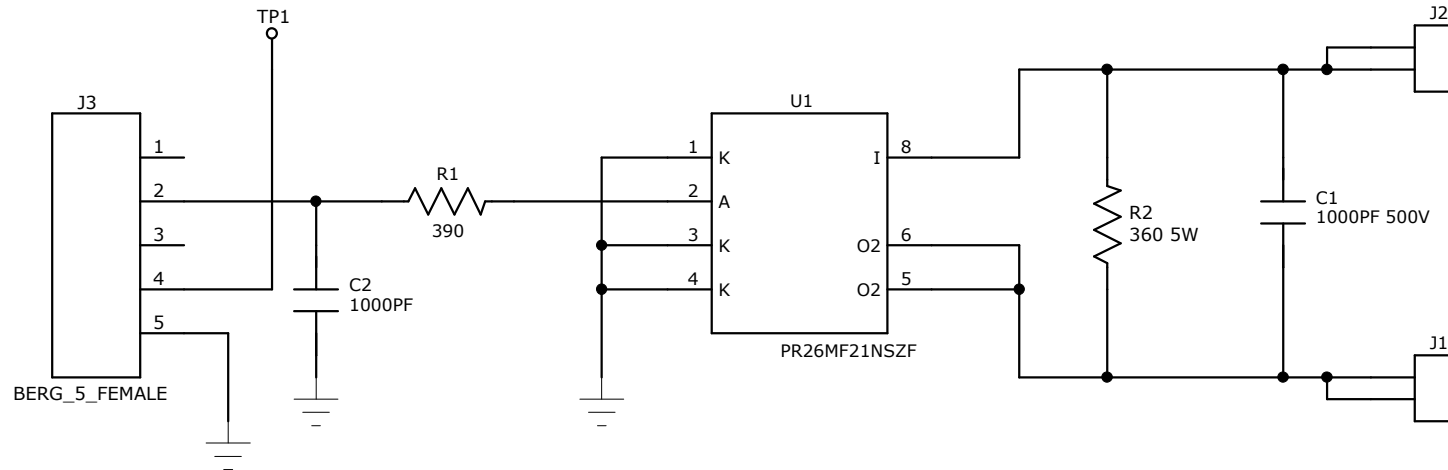

UNLESS OTHERWISE SPECIFIED
 DIMENSIONS ARE IN INCHES
 TOLERANCES ARE:

 .XX +/- 0.01 ANGLE: 0.5
 .XXX +/- 0.001

PROJECT NO. **9500**
 ENGINEER: **G. HARDMAN** DATE: **05/20/08**
 DRAWN BY: **B. FOCKEN** DRAFT DATE: **05/20/08**

ALPHA RADIO PRODUCTS LLC
 6185 ARAPAHOE RD.
 BOULDER, COLORADO 80303
 PHONE: (303) 473-9232
 FAX: (303) 473-9660

PROPRIETARY NOTICE:

 THIS DOCUMENT AND DATA DISCLOSED
 HEREIN AND HEREWITH IS NOT
 TO BE REPRODUCED, USED,
 OR DISCLOSED IN WHOLE OR
 ANY PART TO ANYONE WITHOUT
 THE PERMISSION OF ALPHA RADIO PRODUCTS LLC.

DRAWING FILE:

BCX-X434_REV_1_SCH

 PADS POWERLOGIC DRAWING

TITLE:

SCH, 9500, FAN CONTROLLER

 SIZE **A** DRAWING # **BCX-X434 SHEET1** REV. **1**

 SCALE SHEET 1 OF 1